

# Transmission Grid – High Voltage Metering

Revenue Metering Standing Committee

October 2, 2008



- **Chapter 6 Market Rule amendments**
  - **MR-00342 - Toronto Hydro High Voltage Revenue Metering Proposal**
  - **June 10, 2008**
    - Technical Panel Approval
  - **June 19, 2008**
    - IESO Board Approval
  - **September 10, 2008**
    - Rule amendment in effect

## **Market Manual 3: Metering**

### **Part 3:10: Transmission Grid - High Voltage Metering**

- **October 14, 2008**
  - Draft redline version submitted to Baseline Management
- **October 22, 2008**
  - Posting of draft MM to external Baseline Plan
- **October 22 to November 7, 2008**
  - External Impact Assessment Period
- **November 10 to November 21, 2008**
  - Incorporate impact assessment comments to MM and submit to Legal Services
- **November 24 to December 2, 2008**
  - Incorporate Legal comments and initiate signoff of MM
- **December 10, 2008**
  - Completion of Baseline, MM filed in BIRM and posted on IESO web

- **Market Manual 3: Metering Part 3:10:  
Transmission Grid - High Voltage Metering**
  - Description
  - Hardware requirements
  - Implementation phases
  - Energy settlement details
  - Transmission tariff settlement details
  - Procedure for the application of loss adjustment and load diversity factors
  - Changes requiring review of formulas

1. High Voltage Metering Design, Build and Registration
2. High Voltage Metering Data Collection and Verification of Loss Model Assumptions
3. High Voltage Metering Settlement and Continued Verification of Loss Model Assumptions
4. High Voltage Metering Settlement

Note: Market Manual 3: Metering, Part 3.2; Meter Point Registration and Maintenance process in addition to outlined process in draft Market Manual

## *Low Voltage Metering*

- IESO continues to settle on existing Delivery Points

## *High Voltage Metering*

- Meter Market Participant submits design of high voltage metering configuration
- Meter Market Participant submits system loss model calculation for energy loss adjustment formula and the load diversity formula.
- Registration process set out in Market Manual 3: Metering, Part 3.2; Meter Point Registration and Maintenance followed with additional registration documentation submitted for Energy loss adjustment coefficients and the load diversity adjustment.

# High Voltage Metering Data Collection and Verification of Loss Model Assumptions

## *Low Voltage Metering*

- IESO continues to settle on existing Delivery Points

## *High Voltage Metering*

- High voltage (HV) metering installations are registered in the IESO settlement systems but not used for settlement
- Data collected from the HV metering is compared to the LV metering as per transmission configuration - the purpose is to verify the System Loss Model assumptions
- Duration of one year or as required to satisfy the IESO

# High Voltage Metering Settlement and Continued Verification of Loss Model Assumptions

## *Low Voltage Metering*

- Delivery Points deregistered and no longer used for IESO settlement.
- IESO continues to collect metering data and process to summary meter level
- IESO compares High Voltage Delivery Point meter data to summary meter point data of Low Voltage metering data per transmission configuration provided by the MMP

## *High Voltage Metering*

- Delivery Points for transmission grid high voltage metering registered and used for settlement
- Any changes to the System Loss Model are applied to a going forward basis. No true up or recalculations will be done to previous settlement as a result of changes to the System Loss model.

## *Low Voltage Metering*

- LV metering installations deregistered from IESO systems. Meter data no longer collected

## *High Voltage Metering*

- Delivery Points for transmission grid high voltage metering continue to be settled
- Annual true-ups, for transmission connection charges only, values as agreed to by the MMP and the transmitter
- MMP makes changes to the models – loss and diversity – at the time of a material change and registers the modified formulas with the IESO

- *Energy Settlement*
  - Totalization tables are completed and the Site Registration Reports (SRRs) signed by the MSP and the transmitter (for transmission delivery points only), the energy settlement shall be based on the HV metering data with the loss adjustment formula applied.
  - At a time decided by the IESO, the MMP deregisters the existing meters which are then no longer called by the IESO.

## Generic Settlement Equation for energy settlement

$$DP_E = \left[ \sum M_{HV} + SSLA_{Loss\_Model} \right] - \left[ M_{Participant\ t1} \right] - \left[ M_{Participant\ t2} \right]$$

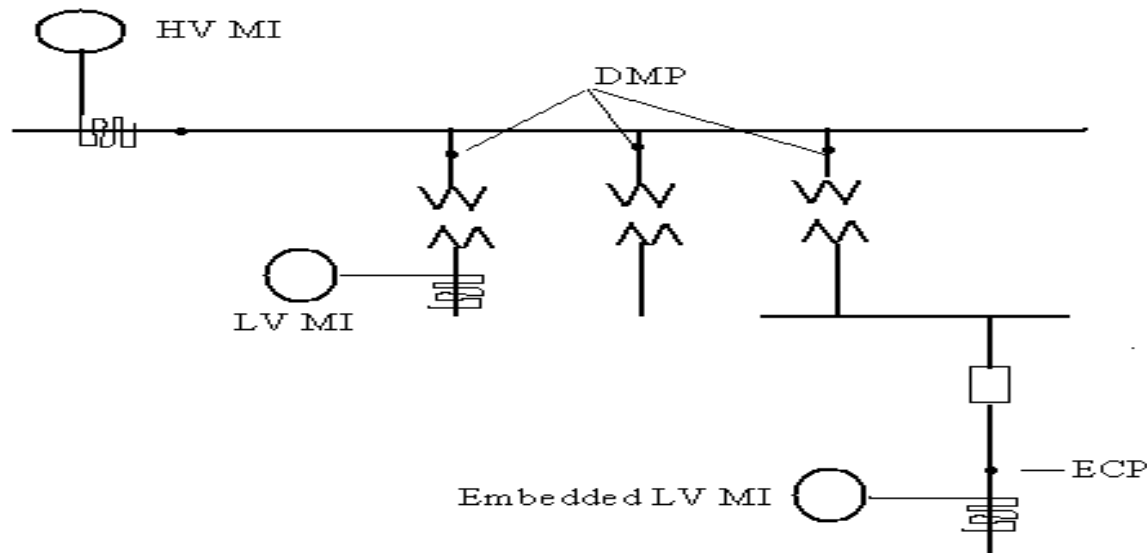

- *Transmission tariff settlement*
  - Transmission charges are based on the HV metering data to which the loss adjustment formula and the load diversity formula is applied.
  - Ongoing requirement from the transmitter to have in place a satisfactory and sustainable means of measurement. The IESO will not be satisfied unless agreement is reached between the MMP and the transmitter on this issue.
  - Periodic true-up for transmission charges with values agreed to by the MMP and the transmitter shall be sent to the IESO to produce a manual line item.

- Generic Settlement Equation for Transmission settlement

$$DP_{TN} = \left[ \sum M_{HV} + SSLA_{Loss\_Model} \right] + SSLA_{TN\_Diversity\_Factor} - \left[ M_{Participant1} \right]$$

$$DP_{TC} = \left[ \sum M_{HV} + SSLA_{Loss\_Model} \right] + SSLA_{TC\_Diversity\_Factor} - \left[ M_{Participant1} \right] - \left[ Embedded\_Generation \right]$$

- **Comments on the proposed Market Manual.**
- **Other?**