



Guide to the Day-Ahead Commitment Process (DACP)

IESO Training
December 2, 2011



Guide to the Day-Ahead Commitment Process (DACP)

AN IESO TRAINING PUBLICATION

This guide has been prepared to assist in the IESO training of market participants and has been compiled using excerpts from the market rules and other documents posted on the web site of Ontario's Independent Electricity System Operator. Users of this guide are reminded that they remain responsible for complying with all of their obligations under the market rules and associated policies, standards, and procedures relating to the subject matter of this guide, even if such obligations are not specifically referred to herein. While every effort has been made to ensure the provisions of this guide are accurate and up to date, users must be aware that the specific provisions of the market rules or other particular document shall govern.

The Independent Electricity System Operator
Box 4474, Station A
Toronto, Ontario
M5W 4E5
Reception: (905) 855-6100
Fax: (905) 403-6921
Customer Relations Tel: (905) 403-6900
Toll Free 1-888-448-7777

www.ieso.ca

Table of Contents

List of Figures	iii
List of Tables	iv
1. Introduction	1
PURPOSE	1
CONVENTIONS	1
BACKGROUND	2
ENHANCEMENTS	2
2. Participation	3
PCG-ELIGIBLE GENERATION FACILITIES	4
3. Registration of Facilities in the DACP	5
OVERVIEW	5
REGISTRATION PROCEDURES BY RESOURCE TYPE	5
DACP REGISTRATION FORMS	6
IMO_FORM_1552 – Real-Time Generation Cost Guarantee and DA-PCG Form	6
IMO_FORM_1181 – Facility Profile	6
IESO_FORM_1702 – Combined Cycle Plant Form	7
IMO_FORM_1004 – Generation Facilities	7
IESO_FORM_1721 – Implementation of Three Part Offers	7
ELIGIBLE ENERGY LIMITED RESOURCE (EELR)	8
PSEUDO UNIT (PSU) MODEL	8
ADDITIONAL GENERATION FACILITY TECHNICAL DATA	9
4. Process Timeline	11
5. Offers and Bids	13
OFFER AND BID STRUCTURE	13
Pseudo Unit Offer Submission	13
Physical Unit Offer Submission	13
Three-Part Offers	13
OFFER AND BID CHANGES	15
AVAILABILITY DECLARATION ENVELOPE (ADE)	16
DAILY GENERATOR DATA (DGD)	18
6. Day-Ahead Calculation Engine (DACE)	20
PASS 1 - COMMITMENT	20
Pass 1 Results	21
PASS 2 - RELIABILITY	21
Pass 2 Results	23
PASS 3 - SCHEDULING	23
Pass 3 Results	23

7. PCG-Eligible Facility Scheduling and Settlement	25
PCG-ELIGIBLE GENERATION FACILITY CONSIDERATIONS	25
DAY-AHEAD PRODUCTION COST GUARANTEE (DA-PCG)	26
DA-PCG OPERATIONAL REQUIREMENTS.....	26
WITHDRAWAL OF DACP COMMITMENT	29
8. Imports, Exports, and Linked Wheels.....	30
IMPORT DAY-AHEAD INTERTIE OFFER GUARANTEE (DA-IOG)	30
DAY-AHEAD IMPORT FAILURE CHARGE (DA-IFC)	32
DAY-AHEAD EXPORT FAILURE CHARGE (DA-EFC)	33
DAY-AHEAD LINKED WHEEL FAILURE CHARGE (DA-LWFC).....	34
9. Publishing and Reporting.....	36
OVERVIEW	36
SYSTEM STATUS REPORTS (SSR)	36
PRE-DISPATCH REPORTS	36
PUBLIC REPORTS	36
MARKET PARTICIPANT CONFIDENTIAL REPORTS	36
DAY-AHEAD SCHEDULE OF RECORD (SOR)	37
DACP FAILURE NOTIFICATION	37
10. Additional Information	38
List of Acronyms	39
Glossary of Terms.....	41

List of Figures

FIGURE 1: DATA SUBMISSION	3
FIGURE 2: ELIGIBLE ENERGY LIMITED RESOURCE (EELR)	8
FIGURE 3: PSEUDO UNIT (PSU) MODEL.....	9
FIGURE 4: FACILITY TECHNICAL DATA	10
FIGURE 5: PROCESS TIMELINE.....	11
FIGURE 6: PRE-DISPATCH TIMELINE	12
FIGURE 7: THREE-PART OFFER AND COST TERMS	14
FIGURE 8: MPI SCREEN – THREE-PART OFFERS.....	15
FIGURE 9: AVAILABILITY DECLARATION ENVELOPE (ADE).....	17
FIGURE 10: MPI SCREEN – DGD	19
FIGURE 11: DAY-AHEAD CALCULATION ENGINE (DACE)	20
FIGURE 12: ENERGY OFFER EVALUATION EXAMPLE: PASS 2 - RELIABILITY	22
FIGURE 13: THREE PASSES OF CONSTRAINED ALGORITHM.....	24
FIGURE 14: MGBRT CONSIDERATIONS	25
FIGURE 15: DA-PCG CALCULATION	27
FIGURE 16: SAMPLE DACP SCHEDULE.....	27
FIGURE 17: REAL-TIME OUTCOME	28
FIGURE 18: DA-IOG CALCULATION	30
FIGURE 19: IOG RATE VS. DAY-AHEAD IMPORT TRANSACTION	31
FIGURE 20: IOG RATE VS. REAL-TIME IMPORT TRANSACTION.....	31
FIGURE 21: DA-IFC CALCULATION	32
FIGURE 22: DA-EFC CALCULATION.....	34
FIGURE 23: DA-LWFC CALCULATION.....	35

List of Tables

TABLE 1: APPLICABILITY OF PROCEDURES	5
TABLE 2: DGD SUBMISSION BY RESOURCE TYPE	18
TABLE 3: GENERATION FACILITY COSTS AND REVENUES	28
TABLE 4: DA-IFC EXAMPLE.....	33
TABLE 5: DA-EFC EXAMPLE	34

1. Introduction

Purpose

This guide describes the design of the Day-Ahead Commitment Process (DACP). This process improves the efficiency of the electricity market through the advanced scheduling and commitment of resources required to provide electricity on a daily basis, while ensuring reliability.

This document is intended to provide a general overview of the DACP. For more detailed information regarding the DACP, please refer to section [10. Additional Information](#), which includes links to supporting reference material.

Both a [List of Acronyms](#) and a [Glossary of Terms](#) have been included at the end of this document in order to explain all acronyms, and to define certain technical terms that may not be immediately familiar to all market participants.

Conventions

The conventions used in this document are as follows:

- “We”, “our”, “us” refers to the IESO and unless otherwise specified, “you”, “your”, and “yours” refers to participants in the IESO-administered markets and the DACP process.
- Time is Eastern Standard Time (EST). The DACP operates on Eastern Standard Time (EST) all year round (e.g., a time stamp in this document of 15:07 means 15:07 EST).
- We use the 24-hour clock and the Hour Ending (HE) convention to identify hours (e.g., HE19 is the hour that starts at 18:00 and ends at 19:00).
- The word “must” denotes a mandatory requirement.
- Italics are used for emphasis and to indicate the titles of publications.
- All prices are in Canadian dollars.
- The term “cost” used in subsequent sections, refers to as-bid and as-offered amounts as submitted by market participants, to consume and produce energy and operating reserve in the market respectively. It does not represent the actual expenditures by a market participant to maintain or generate an electricity-related product.

Background

We originally introduced the DACP in June 2006 to address reliability concerns. The DACP allows the commitment of certain dispatchable resources, and the economic scheduling of imports in the day-ahead time frame, in return for a financial guarantee.

The DACP provides the following:

- A dependable view of the next day's available supply (capacity and energy) and anticipated demand.
- An opportunity for participants to use their energy-limited resources to most effectively meet reliability needs.
- An incentive to imports that have been scheduled day-ahead to flow in real-time.
- An incentive to ensure sufficient internal generation resources are on-line in real-time.
- A way to mitigate the financial risk of commitment for importers and generation facilities.
- A mechanism for us to commit generation facilities, with the participant's agreement, when market-driven attempts don't meet reliability needs.

Enhancements

Changes were later introduced to the DACP in order to enhance the efficiency of the process for scheduling and committing resources, while continuing to ensure reliability.

These new or revised features include the following:

- Optimization of energy and operating reserve over a 24-hour dispatch day.
- Optimization using total costs for *not quick start*¹ generation facilities (i.e., start-up, speed-no-load, and incremental energy costs via three-part offers).
- Revisions to cost guarantee principles.
- Revisions and additions to failure charges.
- Inclusion of exports and linked wheel transactions.
- A model for combined cycle facilities that provides better scheduling of these facilities.
- A daily opportunity to revise certain parameters associated with generation units when the technical characteristics of the facility change.

¹ The term *not quick start* facility is used in this document to refer to a generation facility that does not meet the definition of a *quick start* facility.

2. Participation

We need the following information from market participants in order to create a dependable view of the next day's supply and demand situation (as illustrated in Figure 1), and to make economically sound scheduling and commitment decisions:

- Dispatchable generation facilities must submit *dispatch data*[†] day-ahead if they wish to participate in the next day's real-time market.
- Dispatchable loads must submit dispatch data day-ahead if they wish to participate in the next day's real-time market as dispatchable resources. Loads that do not submit dispatch data day-ahead can still operate in real-time as non-dispatchable.
- Imports, exports, and linked wheels may choose to submit dispatch data day-ahead, but are not obligated to do so.
- Self-scheduling and intermittent generation facilities must submit a schedule or forecast that represents their best estimate of what they plan to produce the next day.
- Combined cycle facilities can choose to submit offers using the combined cycle model known as the Pseudo Unit[†] (PSU) model.

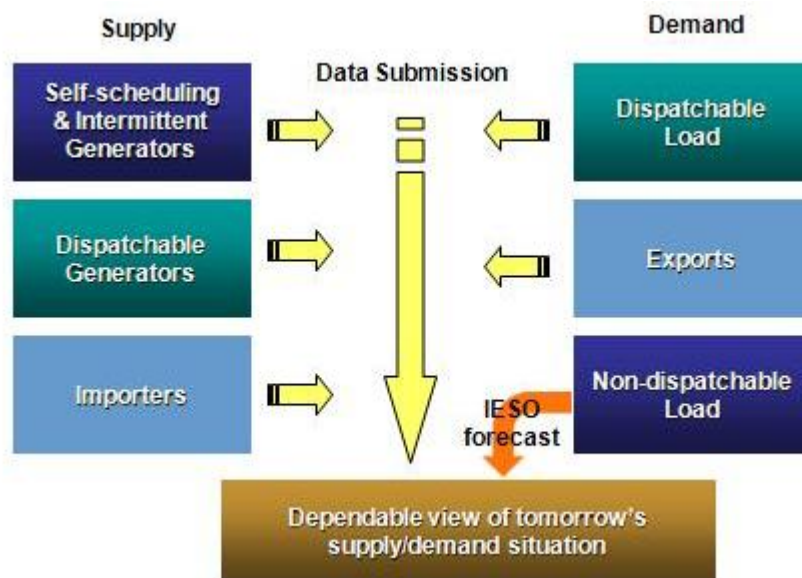

Figure 1: Data Submission

Using this dispatch data, our demand forecast, and other generation facility technical information, we run the Day-Ahead Calculation Engine² (DACE) to create schedules and commitments for the next day.

[†] Refer to the [Glossary of Terms](#).

² For an explanation of the DACE, refer to section [6. Day-Ahead Calculation Engine \(DACE\)](#).

PCG-Eligible Generation Facilities

The DACP schedules all types of resources to meet tomorrow's expected demand. *PCG-eligible facilities*[†] are generation facilities that are eligible to receive a Day-Ahead Production Cost Guarantee[†] (DA-PCG).

A PCG-eligible generation facility must meet all of the following criteria:

- It is not a *quick-start*[†] generation facility.
- It has a Minimum Loading Point[†] (MLP) greater than 0 MW.
- It has a Minimum Generation Block Run-Time[†] (MGBRT) greater than one hour.
- It has an Elapsed Time to Dispatch[†] (ETD) greater than one hour.
- Its *Registered Resource Fuel Type* is not uranium.

[†] Refer to the [Glossary of Terms](#).

3. Registration of Facilities in the DACP

Overview

As part of the DACP registration process, we collect specific operational information in order to determine the following:

- Your resource’s day-ahead commitments and schedules while respecting the resource technical data.
- Your Eligible Energy Limited Resource[†] (EELR) status.
- Your eligibility for the Day-Ahead Production Cost Guarantee (DA-PCG).
- Your DA-PCG settlement amounts³.

To participate in the DACP, you must ensure that you are authorized to participate in the IESO-administered markets, and that the physical facilities which you intend to participate in the DACP have been registered with us in the real-time markets. There are specific registration requirements for dispatchable generation facilities participating in the DACP. All other facilities (i.e., load facilities, boundary entities, and non-dispatchable generation facilities) have no additional registration requirements. You must also indicate to the IESO whether you intend to submit three-part offers⁴.

Registration Procedures by Resource Type

Table 1 lists the registration data submission procedure for each resource type.

Resource Type	Submit DACP Registration Data	Submit CCP and PSU Data
Not Quick Start	X	X ⁵
Pseudo Unit	X	X
Quick Start	X	
TSG; Intermittent; Self-Scheduling	X	
Dispatchable Load	X	

Table 1: Applicability of Procedures

[†] Refer to the [Glossary of Terms](#).

³ For an explanation of DA-PCG settlement amounts, refer to section [7. PCG-Eligible Facility Scheduling and Settlement](#).

⁴ For an explanation of three-part offers, refer to section [5. Offers and Bids](#).

⁵ May submit CCP and PSU data.

DACP Registration Forms

All market participants with registered generation facilities must submit a number of DACP registration forms in order to capture relevant information. This information is then processed by the IESO within six business days of receipt.

IMO_FORM_1552 – Real-Time Generation Cost Guarantee and DA-PCG Form

Not quick start dispatchable generation facilities must complete this form in order to provide us with the following Registered Technical Data (RTD) for each resource:

- Minimum Loading Point (MLP).
- Minimum Run-Time[†] (MRT).
- Minimum Generation Block Run-Time (MGBRT).

Registered MLP and MGBRT values are assumed to be relatively static. They represent the baseline we use to validate changes through the day-ahead daily generator data submissions. Submitted Daily Generator Data[†] (DGD) values are used to schedule *not quick start* resources, to determine DA-PCG commitment actions, and to calculate the DA-PCG. You can view the registered values of your MLP, MRT, and MGBRT through the Facility Registration system.

Registered Technical Data (RTD) is shared with the Real-Time Generation Cost Guarantee[†] (RT-GCG) program. You must, therefore, also indicate whether you want to participate in the RT-GCG program on the same form.

IMO_FORM_1181 – Facility Profile

All generation and load facilities must complete this form in order to provide us with the following DACP-specific registration data:

- Elapsed Time to Dispatch (ETD).
- Daily Cascading Hydroelectric Dependency[†] (DCHD).
- Quick Start facilities.
- Cascading hydroelectric dependent generation resource.

[†] Refer to the [Glossary of Terms](#).

IESO_FORM_1702 – Combined Cycle Plant Form

Generation facilities that are part of a Combined Cycle Plant[†] (CCP) must complete this form in order to provide us with the following information:

- Physical Combustion Turbine (CT) and Steam Turbine (ST) Resource Names and Resource Ids.
- Steam Turbine Percentage Share of Pseudo Unit[†].
- Steam Turbine Duct Firing Capacity[†].
- Steam Turbine MLPs for n-on-1 CT-to-ST configuration⁶.
- Declaration to use Pseudo Unit (PSU) model.

IMO_FORM_1004 – Generation Facilities

All generation facilities must complete this form in order to provide us with the following DACP-specific registration data:

- Primary Fuel Type⁷.
- Secondary Fuel Types⁸.

IESO_FORM_1721 – Implementation of Three Part Offers

This form is used to notify us of your intention to submit three-part offers for the DACP. This declaration is used by IESO systems to determine the version of the Energy Market Graphical User Interface Workspace and Application Programmer Interface (API) offer template file that you use to submit and retrieve dispatch data. This form contains the *Three-Part Offer Eligibility Declaration*.

[†] Refer to the [Glossary of Terms](#).

⁶ The Minimum Loading Point of a steam turbine at a combined cycle plant may differ depending on the number of combustion turbines that obtain a schedule from DACP. For registration purposes, $n-1$ additional ST MLPs are required for all combined cycle configurations above the MLP submitted for a 1 CT on 1 ST configuration; n is equal to the number of combustion turbines at the combined cycle plant. Each value must reflect the technical capability of the generation unit.

⁷ A list of possible fuel types can be found on IMO_FORM_1111 – *NERC Fields-Valid Codes*.

⁸ It is mandatory to submit a single Generator Primary Fuel Type for each generation resource, for registration purposes. You also have the option to submit a single Generator Secondary Fuel Type. The fuel type must reflect the technical capability of the generation resource, and is prohibited if the resource is not a generation resource.

Eligible Energy Limited Resource (EELR)

An Eligible Energy Limited Resource (EELR) can resubmit dispatch data during the DACP process.

An EELR is an Energy Limited Resource (ELR) with the following characteristics:

- It is a cascading hydroelectric generation facility.
- It has a minimum hydraulic time lag to adjacent (upstream or downstream) hydroelectric generation facilities of less than 24 hours (Figure 2).
- The upstream hydroelectric generation facility is operated by the same Registered Market Participant (RMP).

We determine EELR status using the Daily Cascading Hydroelectric Dependency (DCHD) registration data submitted by market participants.

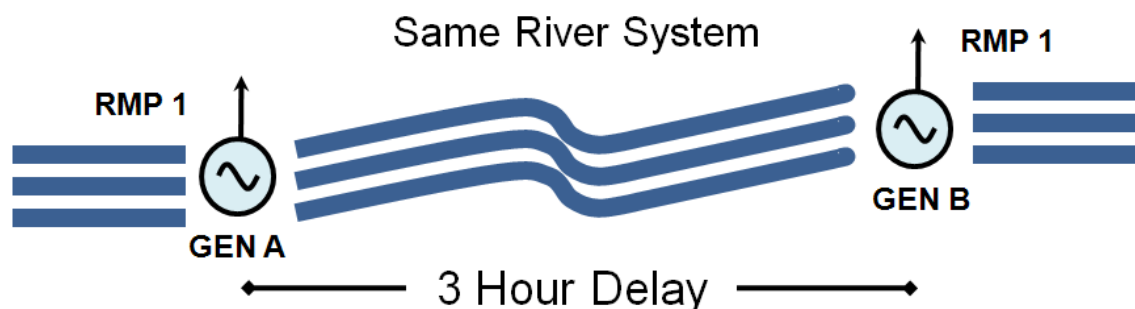

Figure 2: Eligible Energy Limited Resource (EELR)

Once defined as an EELR, a generation unit is deemed eligible to resubmit dispatch data after the initial run of the Day-Ahead Calculation Engine⁹ (DACE), provided that a Daily Energy Limit[†] (DEL) was submitted as part of the day-ahead offer.

For registration purposes, the market participant submits the following information for each dispatchable hydroelectric generation unit:

- A self-declaration that the generation unit has a DCHD.
- The Resource Name and Resource ID of the cascading hydroelectric dependent generation facility.

Pseudo Unit (PSU) Model

Combined cycle generation facilities consist of one or more Combustion Turbines (CT) and a Steam Turbine (ST). The capability of the steam turbine is dependent on the output of the combustion turbines. The dispatch algorithm does not consider these dependencies when determining pre-dispatch and real-time schedules. This can sometimes result in an impractical outcome.

⁹ For an explanation of the DACE, refer to section [6. Day-Ahead Calculation Engine \(DACE\)](#).

[†] Refer to the [Glossary of Terms](#).

The DACP uses a Pseudo Unit (PSU) model to address this issue. The PSU model combines the capability of each CT with a proportional share of the capability of the ST. An illustration of this model for a three-on-one configuration is shown in Figure 3.

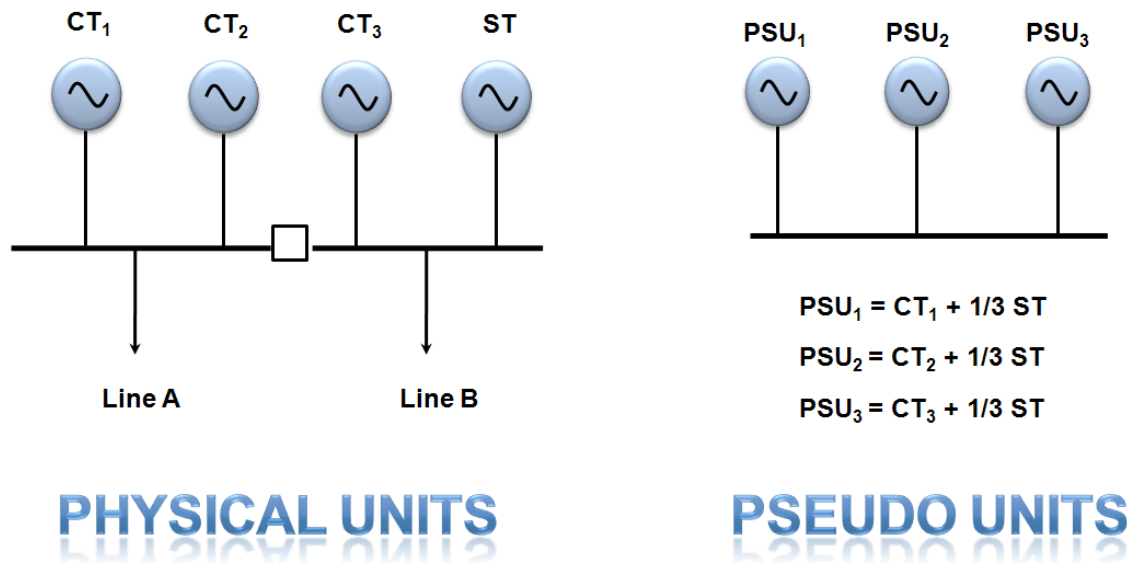

Figure 3: Pseudo Unit (PSU) Model

Participants with a Combined Cycle Plant (CCP) offer into the DACP using pseudo units (i.e., PSU1, PSU2, and PSU3), which allows realistic commitment and scheduling outcomes. The MLP for each PSU is calculated by the IESO as the total of the MLPs for the associated CT plus the MLP of the ST when it is in a 1-on-1 configuration. A program calculates the PSU values based on the information submitted for the CTs and ST of a CCP. The DACE also uses the following values associated with the CT and ST that can be updated daily through the market participant's DGD submission:

- Minimum Generation Block Down-Time[†] (MGBDT).
- Maximum number of starts per day[†].
- Single cycle mode (CT only).
- Minimum Generation Block Run-Time (MGBRT).

The DACP publishes schedules for each of the physical resources (i.e., CT1, CT2, CT3, and ST1) associated with a PSU. Participants continue to use the physical resources to offer in pre-dispatch and real-time.

Additional Generation Facility Technical Data

Dispatchable *not quick start* generation facilities submit additional technical and operational data that reflects their physical capabilities, as shown in Figure 4 (items

[†] Refer to the [Glossary of Terms](#).

marked with an asterisk indicate daily values submitted through Daily Generator Data - DGD).

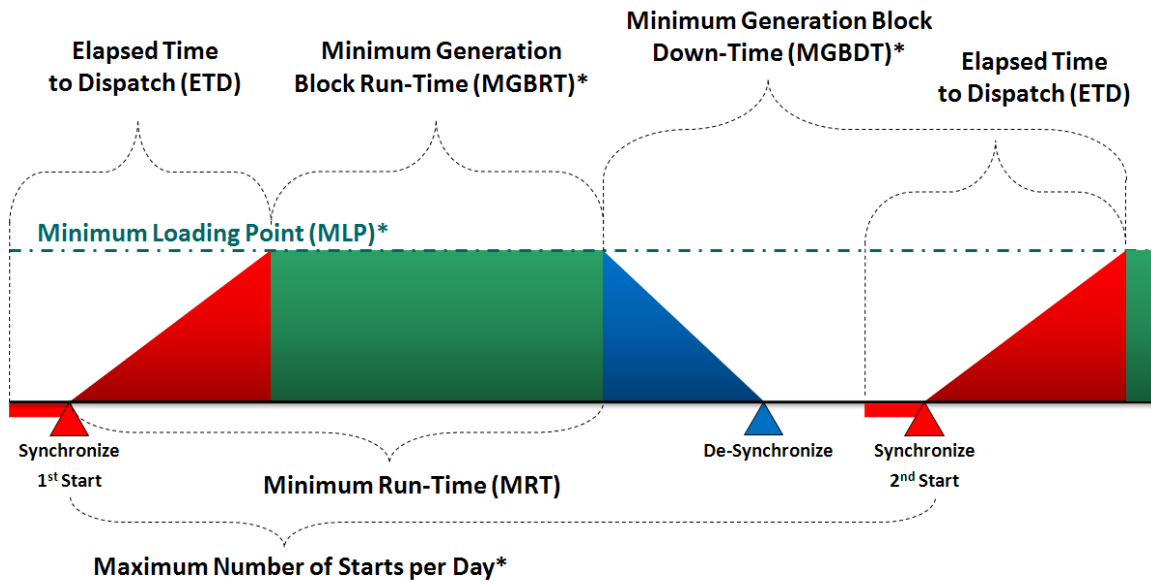

Figure 4: Facility Technical Data

4. Process Timeline

The DACP uses a computational engine that optimizes (i.e., derives the lowest cost supply solution) over the whole day (refer to Figure 5). This increases the calculation time, which has two impacts:

- Any participant that wants to participate in the day-ahead commitment process must submit dispatch data by 10:00 day-ahead to allow sufficient time for the calculations and publishing of final results by 15:00.
- Multiple runs of the computational engine occur between 10:00 and 15:00. The results of each run are published via the *Market Data* and *Market Data DACP Reports* sections of the IESO reports web page (refer to section [10. Additional Information](#) for direct links to these resources).

An EELR has one opportunity to revise its offer following the first DACP run. This allows the EELR to address any sub-optimal scheduling of its resources.

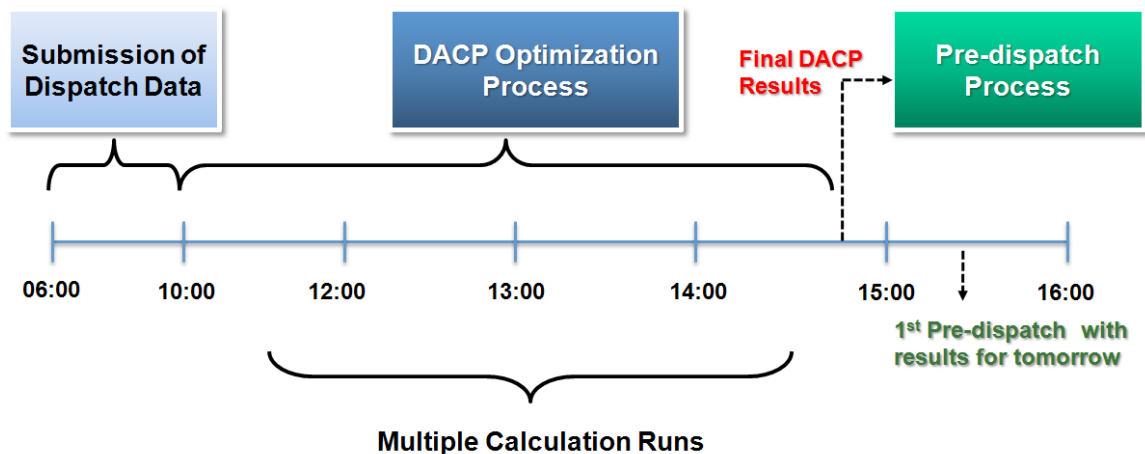

Figure 5: Process Timeline

Pre-dispatch is run hourly. Pre-dispatch results for the next day are not published during the DACP process (from 10:00 -15:00). Results from the 15:07 pre-dispatch run incorporate the commitment outcomes from the DACP and provide the first pre-dispatch schedule showing the hours for the next day (refer to Figure 6).

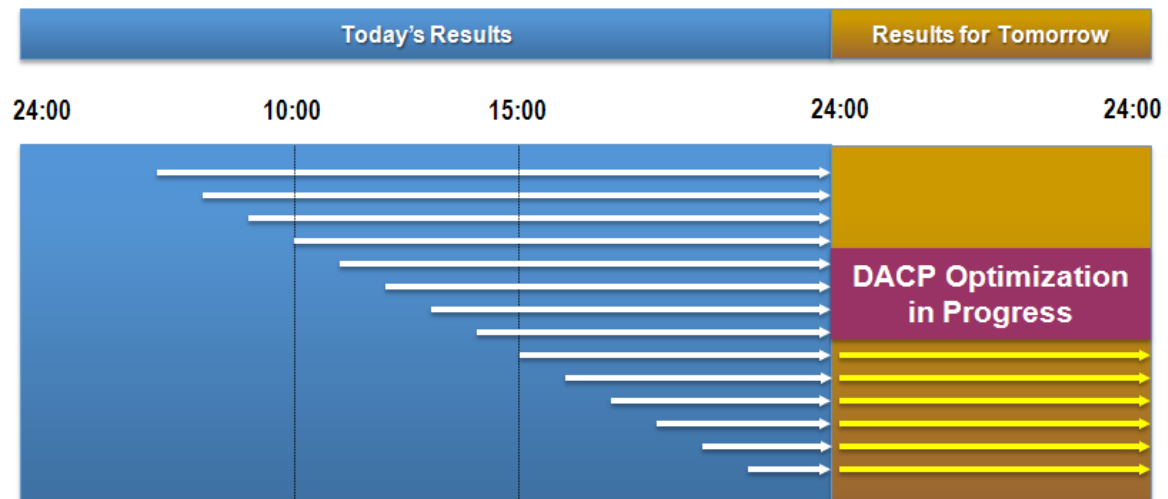

Figure 6: Pre-Dispatch Timeline

The timeline is characterized by the following:

- MPs wishing to participate in the DACP must submit dispatch data by 10:00.
- DACP results are published after each run.
- The DACE is a separate calculation engine from pre-dispatch – pre-dispatch continues to run hourly.
- Once the DACP has finished and results have been passed to the 15:07 pre-dispatch, pre-dispatch results are published showing the hours of tomorrow.

5. Offers and Bids

Offer and Bid Structure

Market participants may submit offers in the following manner:

- **PCG-Eligible Generation Facilities** - May submit three-part offers, which allow a total cost comparison and enable efficient scheduling and commitment decisions.
- **Other Not Quick Start Generation Facilities** - May submit three-part offers, which allow a total cost comparison and enable efficient scheduling decisions (these resources are not eligible for a DA-PCG).
- **Dispatchable Not Quick Start Generation Facilities** - May revise certain generation parameters daily if the technical characteristics of the facility change.
- **Other Dispatchable Generation Facilities, Dispatchable Loads, Imports, and Exports** - Continue to provide single-part offers.

Pseudo Unit Offer Submission

Day-ahead offers for the PSU resource must be submitted by 10:00 (i.e., in time for the first DACE run of the day). PSU offers can be submitted as either standing offers (i.e., before 06:00) or anytime between 06:00 and 10:00 day-ahead.

Physical Unit Offer Submission

Real-time offers for physical unit resources that comprise a PSU must be submitted by 10:00 day-ahead. Physical unit offers can be submitted as either standing offers (i.e., before 06:00) or anytime between 06:00 and 10:00 day-ahead. For each physical unit associated with a PSU, the physical unit offer at 14:00 determines the ADE for that resource. You must ensure that the ADE established for your physical units is sufficient to cover the physical unit schedules that you receive from the DACP.

Three-Part Offers

The new DACE¹⁰ compares total costs when making commitments.

PCG-eligible generation facilities and other *not quick start* generation facilities may provide three-part offers that reflect all of their costs as follows (refer to Figure 7):

1. Start-up Cost.
2. Speed-No-Load Cost.
3. Incremental Energy Cost.

¹⁰ For an explanation of the DACE, refer to section [6. Day-Ahead Calculation Engine \(DACE\)](#).

Fixed costs are represented as follows:

- **Start-up Cost** - The cost incurred to bring an off-line generation unit through all of the unit-specific start-up procedures, including synchronization and ramp up to MLP.
- **Speed-No-Load Cost** - The cost to maintain a generation unit synchronized with zero net energy injected into the system for an hour (the speed-no-load cost and the incremental offer for energy up to a generation unit’s MLP form its minimum generation cost).

PCG-eligible generation facilities use price-quantity pairs to reflect their incremental energy costs. Once the DACP commitment is complete, only the incremental energy offer (i.e., the price-quantity pairs) is transferred to the pre-dispatch and real-time dispatch algorithms.

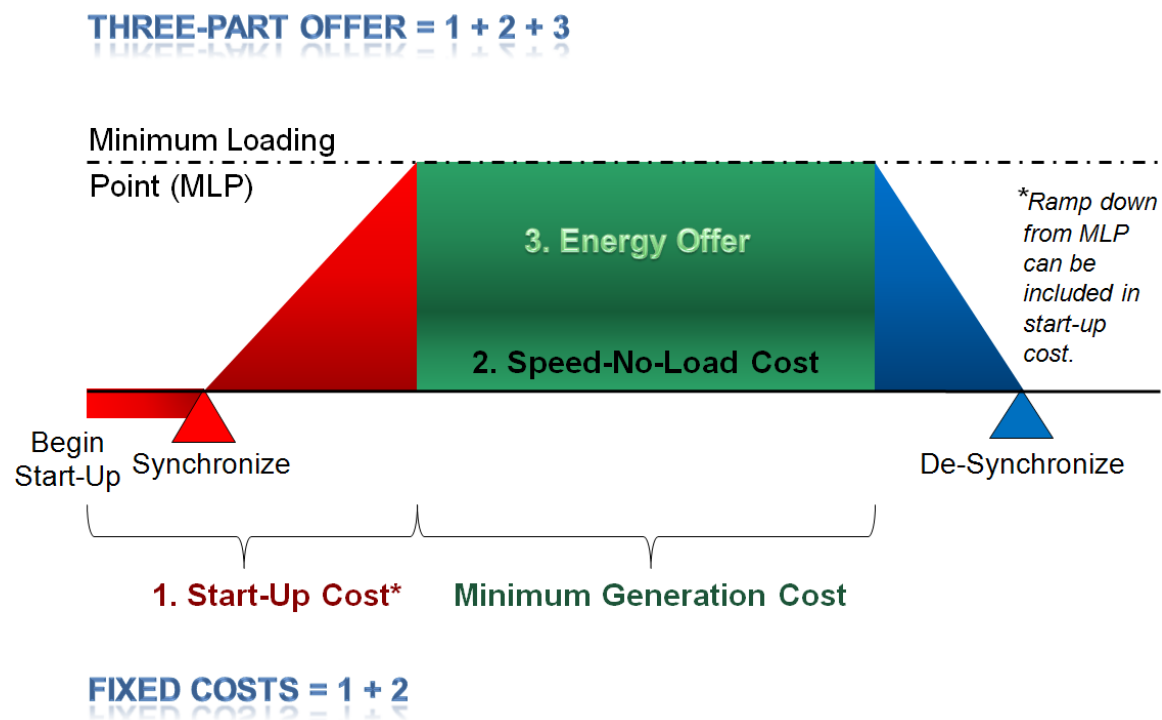

Figure 7: Three-Part Offer and Cost Terms

An example of the Real-Time Energy Market (RTEM) display is shown in Figure 8. This section of the Energy Market Graphical User Interface Workspace includes the interface for the RTEM bid type showing speed-no-load (column heading SNL) and start-up costs (column heading SUC).

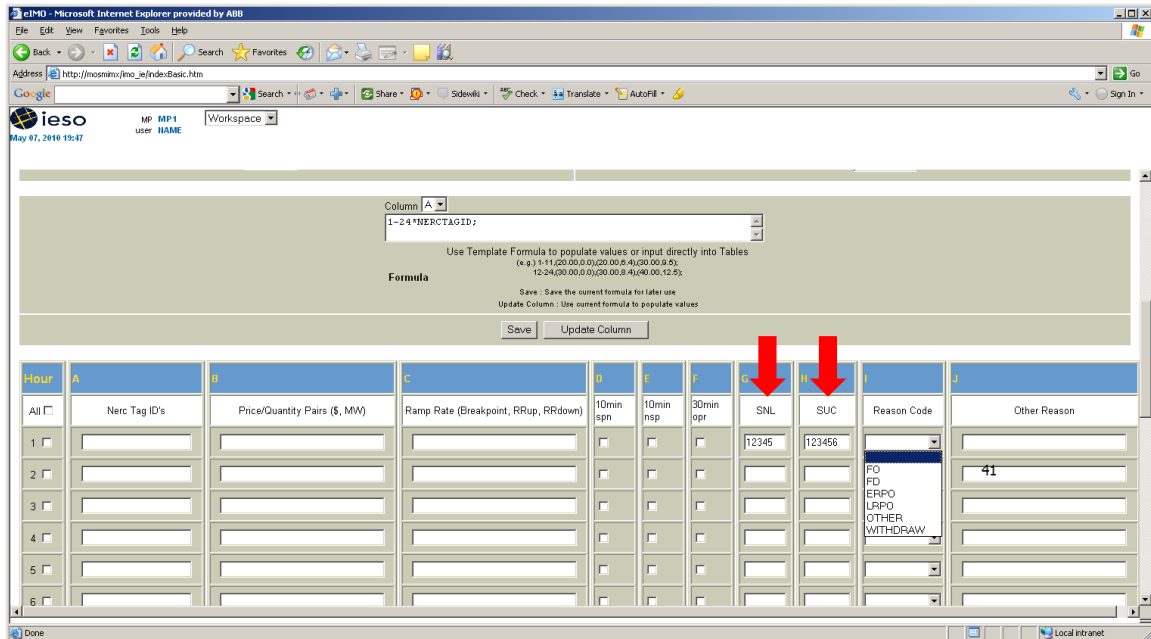

Figure 8: MPI Screen – Three-Part Offers

Offer and Bid Changes

We accept dispatch data submissions during the DACP optimization process (between 10:00 and 14:00) from the following:

- Non-dispatchable generation facilities (forecasts and schedules).
- Physical units associated with a PSU (i.e., the physical CT and ST that make up a PSU) to assist in pre-dispatch and real-time scheduling.
- EELRs that pass standard validation rules.

You must include a reason code for dispatch data submissions between 10:00 and 14:00 from all other dispatchable generation facilities and dispatchable loads (see *Appendix A, Market Manual 9.2* for a list of valid reason codes). If you do not include a reason code, the bid/offer is automatically rejected and a validation error is issued.

Cascade hydroelectric generation units that are energy limited may be scheduled in a sub-optimal way. For this reason we give EELRs that submit a Daily Energy Limit (DEL) prior to 10:00 an opportunity to look at the results of one complete run of the DACE, and we allow EELR offers including the DEL to be adjusted. During the EELR re-submission window (normally from 11:00 to 12:00), restrictions do not apply to dispatch data changes from EELRs.

You do not need our approval for changes to offers for physical units associated with a PSU when these changes occur between 10:00 and 14:00. You must ensure that the offers for your physical units are sufficient to allow the physical unit schedules you receive from the DACP to be scheduled in Pre-dispatch.

Availability Declaration Envelope (ADE)

The ADE is the hourly energy offered into the DACP for dispatchable generation facilities, or the hourly load bid as dispatchable for dispatchable loads.

Once the Availability Declaration Envelope (ADE) is established, participants may not increase either the quantity or hours of their offers or bids after their initial DACP submission, except under specific circumstances.

The ADE applies to dispatchable generation facilities and dispatchable loads (the notion of the ADE does not apply to non-dispatchable generation facilities, non-dispatchable loads, imports, or exports).

Offers for operating reserve into the DACP must be accompanied by a corresponding energy offer (or a bid for dispatchable loads). While there is no ADE for Operating Reserve (OR), the ADE of the corresponding energy offer/bid impacts the amount of OR that you can offer in real time.

The ADE is established for the next dispatch day by the most recent dispatch data that was considered and approved in the DACP Schedule of Record (SOR).

If you are a dispatchable generation facility, you may submit offers in real time within the hours, energy, and capacity of your facility's ADE. There are no restrictions on price changes within the ADE (except where a change may affect eligibility for a real-time guarantee program) and there are no restrictions on daily energy limit changes within the ADE. However, offers exceeding the hours and/or quantities of the ADE require our approval.

If you are a dispatchable load, you may submit bids in real time (and corresponding offers for OR) within the hours and dispatchable load quantities of your facility's ADE. There are no restrictions on price changes within the ADE. However, bids (and offers for OR) exceeding the hours and dispatchable load quantities of the ADE require our approval.

We approve the submission of new or revised dispatch data that increases the ADE for dispatchable generation or dispatchable load facilities for the following reasons:

- If the facility is returning early from planned or forced outages, forced de-ratings, or cancellation of planned outages.
- If we requested additional bids and offers (in which case, you do not need to call us).
- If such increases to your facility’s ADE resolve emerging reliability concerns.

For the late start of a planned outage, we accept the dispatch data submitted, but we do not approve the expansion of your ADE. The submission is logged to compliance for follow up.

An ADE is established by the offers used in the DACP Schedule of Record (SOR). In the example shown in Figure 9, the unit has declared that it will be available tomorrow between HE 9 and HE 20 with up to 230 MW. Later offer changes are restricted by this day-ahead offer.

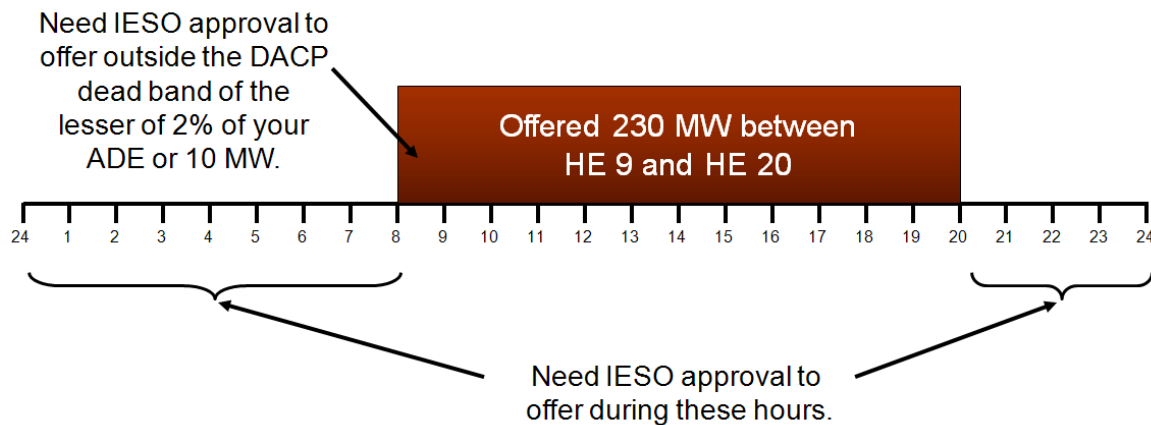

Figure 9: Availability Declaration Envelope (ADE)

If scheduled during the DACP, committed units are scheduled to at least their MLP in all subsequent schedules for tomorrow (i.e., pre-dispatch and real-time). We put a constraint in the system so the unit is scheduled to be at its MLP at the start of the unit’s MGBRT. The constraint starts in the first hour indicated in the *Day-Ahead Commitments* report.

Daily Generator Data (DGD)

The DACE requires Daily Generator Data (DGD) values for dispatchable *not quick start* generation facilities. The DACE initializes DGD with the default values as shown in Table 2.

Data Description	Unit of Measure	Default Value	Not Quick Start Generation Facility	Quick Start Generation Facility	Non-Dispatchable Resources
Minimum Loading Point	MW	0	X	n/a	n/a
Minimum Generation Block Run-Time	Hours	0	X	n/a	n/a
Minimum Generation Block Down-Time	Hours	0	X	n/a	n/a
Maximum Number of Starts per Day	Number	24	X	n/a	n/a
Single Cycle Flag ¹¹	Yes/No	No	X	n/a	n/a

Table 2: DGD Submission by Resource Type

Not quick start generation facilities can submit revised baseline DGD through the offer/bid submission tools on a daily basis. DGD remains the same as the most recently submitted value unless otherwise updated.

Revised DGD must be submitted before 10:00 day-ahead. No approval is required if these revised DGD values are within registered MLP and MGBRT limits[†]. IESO approval is required if DGD exceeds MLP and MGBRT limits.

¹¹ Only applies to CTs associated with PSUs.

[†] Refer to the [Glossary of Terms](#).

An example of the Daily Generator Data (DGD) display is shown in Figure 10. This section of the Energy Market Graphical User Interface Workspace allows the creation/editing of DGD as required.

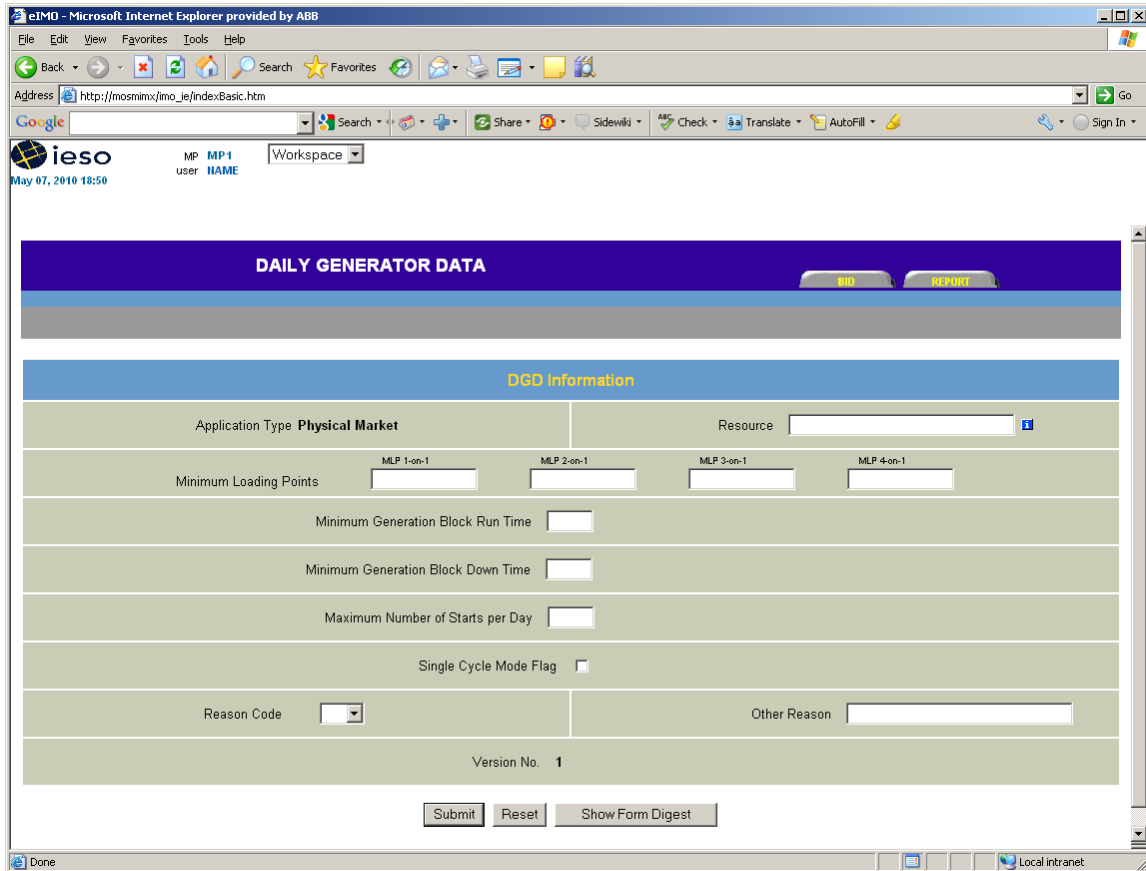

Figure 10: MPI Screen – DGD

6. Day-Ahead Calculation Engine (DACE)

The Day-Ahead Calculation Engine (DACE) co-optimizes energy and operating reserve over the 24 hours of the next day. It uses dispatch data, IESO inputs, and additional data from PCG-eligible generation facilities and other *not quick start* generation facilities to determine commitments and schedules.

Each run of the DACE consists of three passes, as shown in Figure 11.

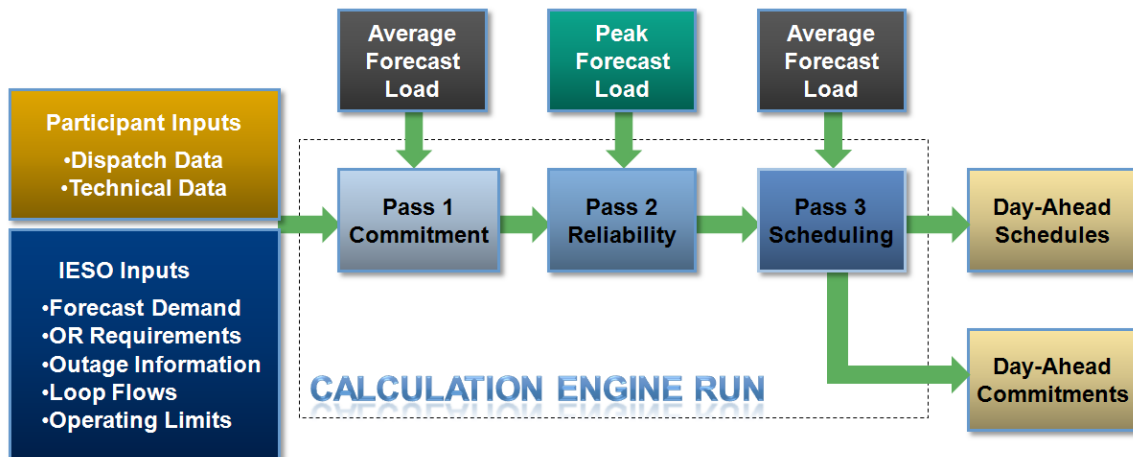

Figure 11: Day-Ahead Calculation Engine (DACE)

Pass 1 - Commitment

In Pass 1, resource schedules are chosen that serve average hourly demand over the next day at the lowest possible total cost. Average demand is used in this pass so that resources are not over-committed.

We assume that *quick start* generation facilities have no commitment costs – we consider only their energy and operating reserve offers. Similarly, we schedule imports, exports, and linked wheels based on the economics of their offers and bids.

We schedule PCG-eligible and other *not quick start* dispatchable generation facilities based on the following:

- Their total costs as submitted through their three-part offers.
- Their operational restrictions, such as MGBRT or MLP, provided through their additional data submissions.

Pass 1 Results

Pass 1 results are as follows, and are used as inputs to Pass 2:

- Schedules for dispatchable loads based on their bids.
- Schedules for imports, exports, and linked wheels based on their offers and bids.
- Schedules for PCG-eligible generation facilities and other *not quick start* generation facilities based on their total cost to supply – these schedules respect all submitted technical and operational limitations.
- Schedules for other dispatchable generation based on their offers.
- Schedules and forecasts of self-scheduling and intermittent generation facilities as submitted by them.

Pass 2 - Reliability

The objective of the second pass is to ensure that we have sufficient capacity and energy to meet our hourly peak demand for the next day, again at the lowest possible cost. Normally, peak occurs over a single 5-minute interval, which is taken into account when Pass 2 determines which resources to commit in order to meet this need.

Pass 2 uses the schedules and commitments from Pass 1 and chooses the lowest cost solution from the following options in order to cover peak:

- Ramp up a quick-start or already committed *not quick start* generation facility.
- Ramp down a dispatchable load.
- Schedule an import for the hour (and reduce generation in the other non-peak intervals).
- Reduce an export for the hour (and reduce generation in the other non-peak intervals).
- Schedule an additional PCG-eligible generation facility as necessary.

Note: We do not reduce imports from their Pass 1 quantity¹².

In most hours, peak occurs for only one interval. The peak can be served by either ramping up dispatchable generation resources for the interval or by scheduling an hourly import, while backing down generation for other intervals. Similarly, a dispatchable load can be ramped down for an interval or an export can be reduced for an hour.

However, the calculation engine commits and schedules for an hourly basis. In order to properly assess (on an equivalent basis) whether to ramp a dispatchable resource for an

¹² Imports committed in Pass 1 are scheduled to no less than their Pass 1 amounts; the import amounts scheduled in Pass 1 are already eligible for Day-Ahead guarantees. If a Pass 2 import schedule is greater than its Pass 1 schedule, the entire Pass 2 import schedule is eligible for the Day-Ahead guarantee. Additionally, if required, new imports or additional PCG-eligible generation that did not receive a commitment from Pass 1 may be committed in Pass 2.

interval or to schedule an hourly intertie transaction, Pass 2 performs a least-cost security constrained commitment to satisfy peak for one interval. It does this by assessing offers/bids from dispatchable resources in the following manner:

- The incremental offers from *not quick start* facilities committed in Pass 1 and all offers from *quick start* facilities that are greater than their *shadow prices*[†] in Pass 1 are evaluated as shown in the example in Figure 12 (this serves to average out the cost per interval).
- Bids for dispatchable loads are treated in a similar manner.

$$\text{COST} = \text{PASS 1 SHADOW PRICE} + (\text{OFFER} - \text{PASS 1 SHADOW PRICE})/12$$

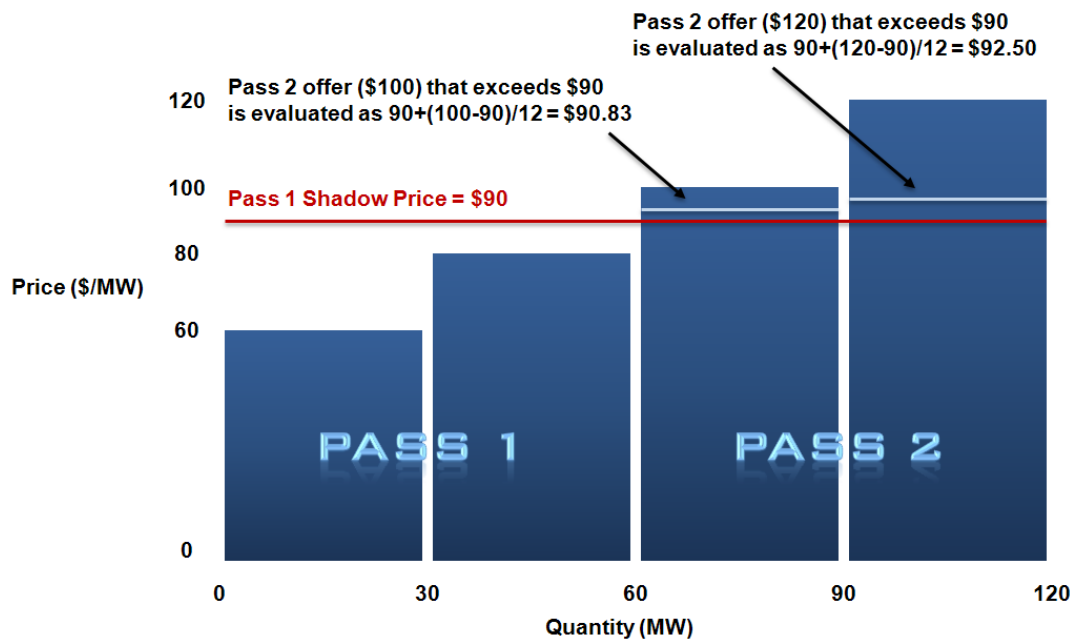

Figure 12: Energy Offer Evaluation Example: Pass 2 - Reliability

In this example (Figure 12), a generation facility is scheduled to 60 MW in Pass 1.

- Its Pass 1 shadow price is \$90/MW.
- Pass 2 offers that exceed \$90/MW are assessed as the Pass 1 shadow price plus one twelfth of the difference between the offer and shadow price.

[†] Refer to the [Glossary of Terms](#).

Of that generation facility's remaining capacity:

- Up to 30 more MW is available at \$90.83/MW.
- From 30-60 more MW is available at \$92.50/MW.

Pass 2 Results

Pass 2 results reflect the additional energy required to meet the hourly peak demands. Unless this involves scheduling an additional PCG-eligible generation facility or import, or reducing an export, this schedule has the same resources as Pass 1 – they are simply dispatched differently to meet the peak.

Pass 2 results are used as inputs to Pass 3.

Pass 3 - Scheduling

Pass 3 has the same objective as Pass 1 (to meet average hourly demand), but it must consider the results of Pass 2. If Pass 2 was satisfied by ramping up already committed generation facilities from Pass 1, then Pass 3 results are identical to Pass 1 results.

Pass 3 respects the following rules to minimize commitment costs:

- PCG-eligible generation facilities and other *not quick start* generation facilities scheduled in Passes 1 and 2 that submitted an MLP are scheduled to at least that level.
- Imports are scheduled to at least their Pass 2 schedules.
- Exports are scheduled to no greater than their Pass 2 schedules.
- The energy associated with *not quick start* generation facilities ramping to their MLPs (in the hour before the first commitment hour) is considered when determining the schedules for all resources.

Note: For the export and import legs of a linked wheel, we ensure that the energy scheduled is equal.

Pass 3 Results

Pass 3 results are the final day-ahead commitment schedules.

Results are passed to pre-dispatch for use in the 15:07 run. PCG-eligible generation facilities are constrained to at least their MLP for all hours of their DACP schedule in all subsequent pre-dispatch and real-time runs.

The result of the DACP optimization is a set of commitments for PCG-eligible generating resources and schedules for imports necessary to meet reliability requirements, along with constrained schedules for all resources to meet forecasted average demand.

An overview of the three passes is depicted in Figure 13 below.

START OF DACP OPTIMIZATION AT 10:00

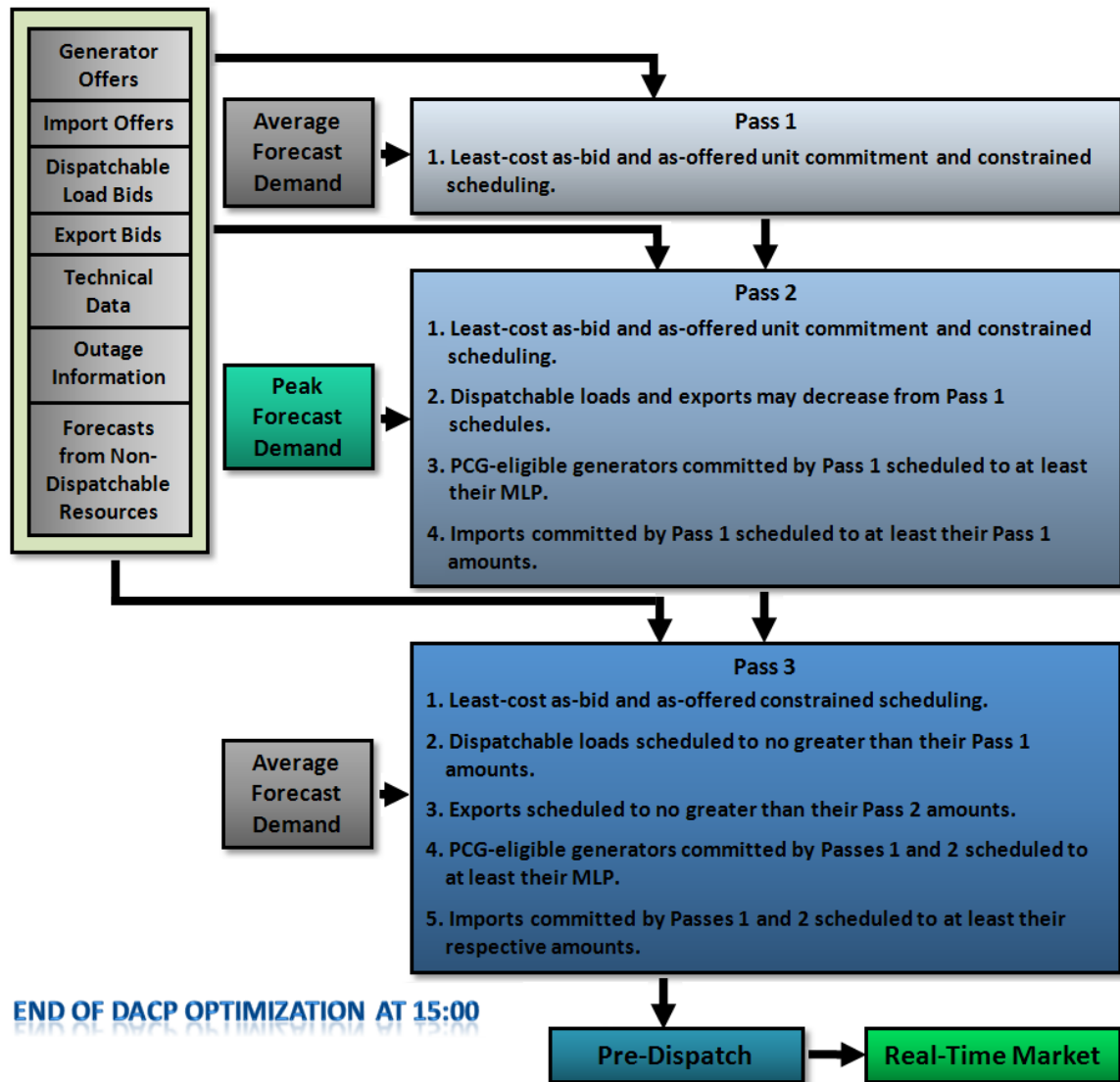

Figure 13: Three Passes of Constrained Algorithm

In summary, the DACE includes the following features:

- The DACE is a calculation engine that minimizes total commitment costs and optimizes over 24 hours.
- Exports, linked wheels, and three-part offers from PCG-eligible generation facilities are considered.
- PCG-eligible generation facilities are constrained to at least their MLP for all hours of their DACP schedule in all subsequent pre-dispatch and real-time runs.

7. PCG-Eligible Facility Scheduling and Settlement

PCG-Eligible Generation Facility Considerations

The DACP commits a generation facility even if its MGBRT extends past midnight (refer to Figure 14). When the DACP runs the next day, it recognizes the need to complete MGBRT as long as the participant has submitted offers for those hours.

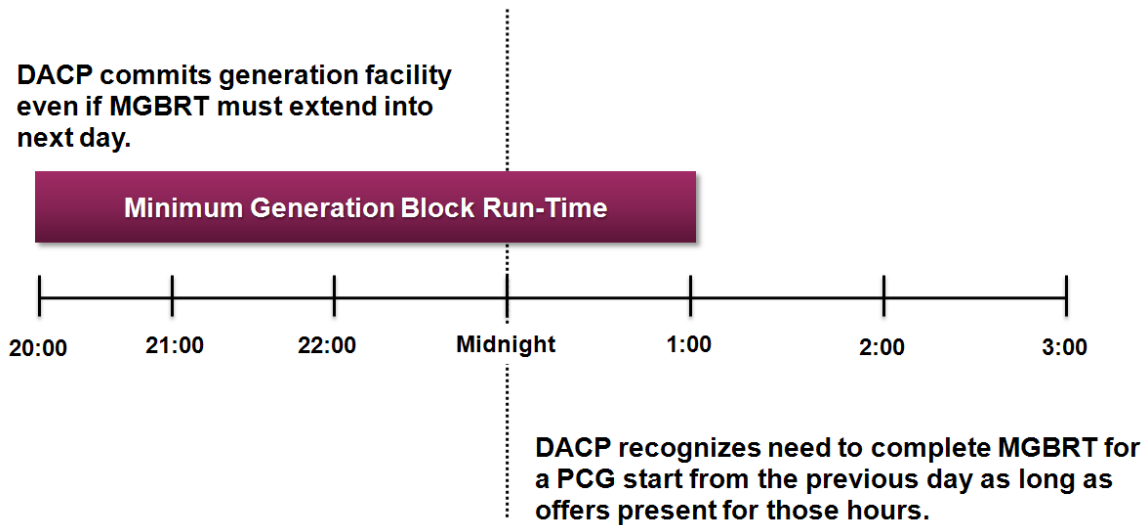

Figure 14: MGBRT Considerations

PCG-eligible generation facilities may submit escalating start-up offers at the end of the DACP day to receive start-up, speed-no-load, and incremental energy for the MGBRT up to the MLP within that day. This ensures that the causality of a start is attributed to the day in which the start occurs. The escalating start-up costs submitted by the market participant may include anticipated Day 1 revenues.

The DACP respects all Minimum Generation Block Down-Times (MGBDT) within a day, but does not recognize when a generation facility needs to remain shut down past midnight to satisfy this requirement. The participant's *offer strategy*¹³ must ensure that MGBDT is respected over midnight.

¹³ e.g., The participant does not offer for the period required to satisfy the MGBDT.

Day-Ahead Production Cost Guarantee (DA-PCG)

The Day-Ahead Production Cost Guarantee (DA-PCG) allows cost recovery for PCG-eligible generation facilities if real-time revenue does not cover the generation facility's as-offered costs for the hours included in the DACP schedule. *The DA-PCG cannot be rejected.* It is based on the total day-ahead schedule. All cost information is submitted before the DACP runs at 10:00.

DA-PCG Operational Requirements

To be eligible for a DA-PCG (for a DACP start event) a generation facility must:

- Have its generator breaker closed by the start of the 1st interval of the 1st DACP scheduled hour.
- Not have a withdrawal within the market participant's control for any hour in the DACP start event.

For settlement purposes, the breaker close for the generation unit is identified by using revenue meter data (a generation unit is considered to have closed its breaker when revenue meter data indicates a value greater than zero that is sustained for four consecutive intervals).

The start-up cost component of the DA-PCG is calculated based on when the generation unit achieves MLP as follows:

- **Scenario 1** - If the generation unit achieves MLP within the first 6 intervals of the start of the DACP scheduled period, the full as-offered start-up cost is considered.
- **Scenario 2** - If the generation unit achieves MLP between the start of the 7th interval and before the start of the 18th interval of the start of the DACP scheduled period, the as-offered start-up cost is calculated on a fractional basis (the as-offered start-up cost is calculated based on the number of 5-minute intervals the resource takes to achieve MLP between the start of 7th interval and before the start of the 18th interval).
- **Scenario 3** - If the generation unit achieves MLP after the 17th interval of the start of the DACP scheduled period, the as-offered start-up cost is not considered.

The DA-PCG is calculated as shown in Figure 15.

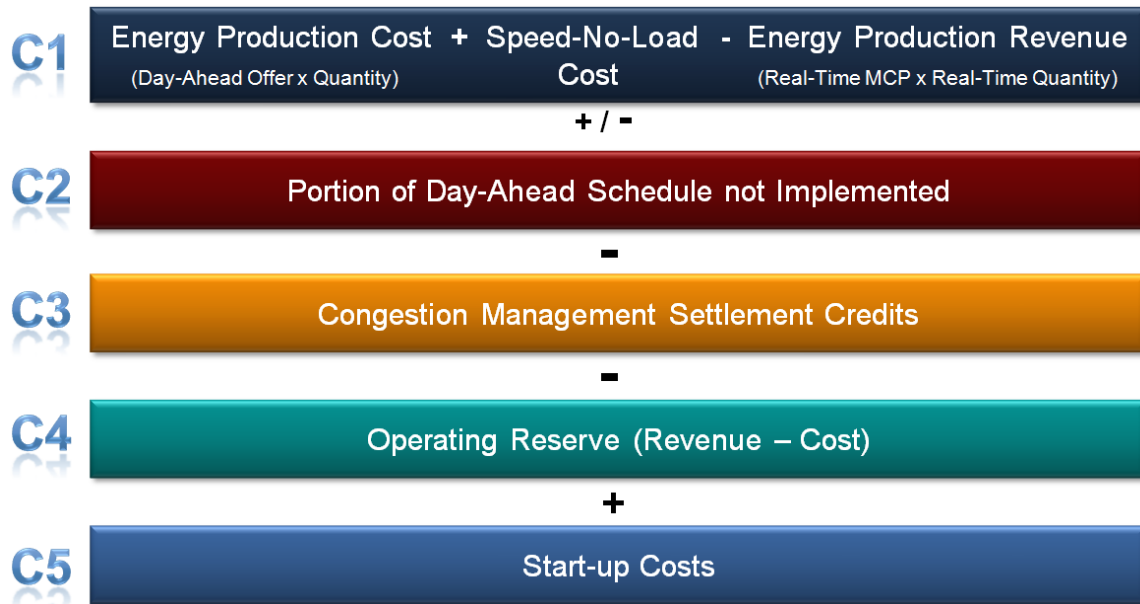

Figure 15: DA-PCG Calculation

Assume that a generation facility receives the following schedule from the DACP (see Figure 16):

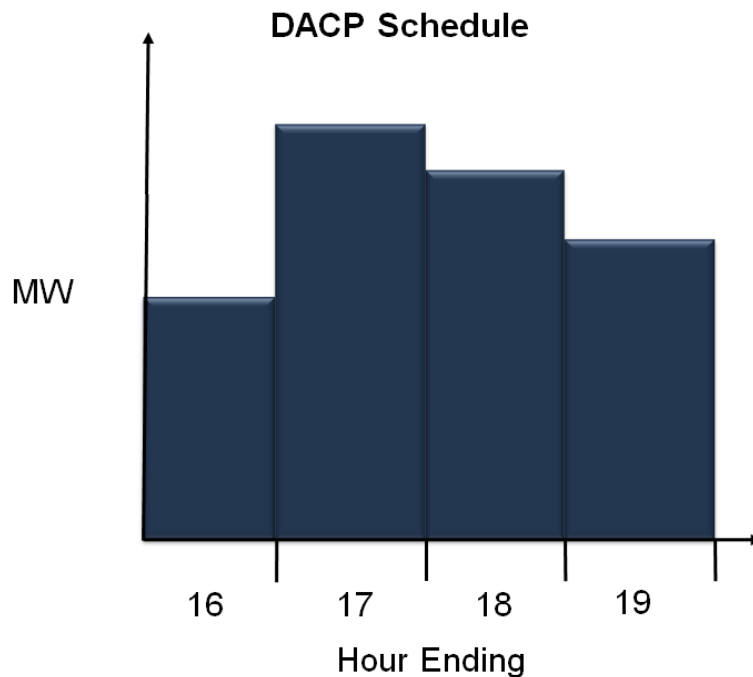

Figure 16: Sample DACP Schedule

The generation facility’s real-time outcomes compared to its DACP schedule are shown in Figure 17. In this example, the generation facility does the following:

- ◆ It produces energy to meet its dispatch instructions.
- ◆ It does not implement a portion of its day-ahead schedule for hour 17.
- ◆ It is partially constrained for hours 17 and 18.
- ◆ It is scheduled for operating reserve.

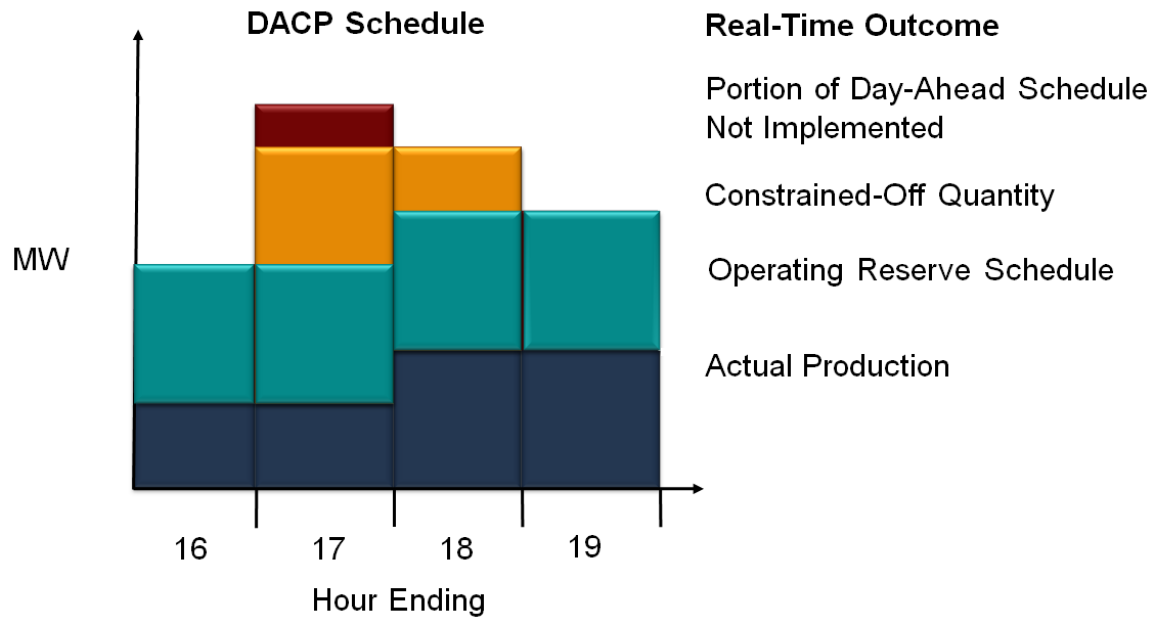

Figure 17: Real-Time Outcome

The DA-PCG for a generation facility is based on the generation facility’s costs to meet its DACP schedule and the associated revenues from that schedule

Costs (+)	Revenues (-)
Energy Production Costs (Day-Ahead Energy Offer x Quantity)	Energy Production Revenues (Real-Time Energy Market Clearing Price (MCP) x Quantity Injected)
Portion of Day-Ahead Schedule not Implemented in Real-Time	
Congestion Management Settlement Credits	
Operating Reserve Costs (Real-Time OR Offer x Quantity)	Operating Reserve Revenues (Real-Time OR MCP x Quantity + OR CMSC)
Start-up Costs	

Table 3: Generation Facility Costs and Revenues

The portion of the day-ahead schedule not implemented in real-time can either add to or subtract from the DA-PCG. We compare the participant's real-time offer against their day-ahead offer in order to determine whether they attempted to get scheduled to meet their day-ahead commitment.

For the portion of the day-ahead schedule not implemented in real-time, if the participant's real-time offer price is:

- Equal to their day-ahead offer, then this component is zero.
- Greater than their day-ahead offer, then this component subtracts from the DA-PCG.
- Less than their day-ahead offer, then this component adds to the DA-PCG.

The DA-PCG includes the following features:

- PCG-eligible generation facilities cannot reject the cost guarantee.
- It is based on the entire DACP schedule, not just MLP for MGBRT.
- It includes the unimplemented portion of the day-ahead schedule.

Withdrawal of DACP Commitment

Committed generation facilities that withdraw their commitment after the Schedule of Record (SOR) is published may incur a charge. This ensures that treatment of generation facilities is consistent with treatment of imports and exports, which are charged for failing to meet their day-ahead commitments.

The charge applies if the following occur:

- A generation facility withdraws before completing its day-ahead commitment.
- The reason for withdrawal is within the generation facility's control.

The formula used to determine the charge is based on how much advance notice of the withdrawal the participant provides.

If notification is given more than four hours ahead of real-time, the market has time to respond to the withdrawal; therefore, we base the charge on the lower of the hour-ahead pre-dispatch or real-time MCP.

If notification is given less than four hours ahead of real-time, we use the real-time MCP for the entire calculation.

8. Imports, Exports, and Linked Wheels

Import Day-Ahead Intertie Offer Guarantee (DA-IOG)

Imports may offer in real-time regardless of whether or not they offer into the DACP. Imports scheduled in the DACP are eligible to receive a Day-Ahead Intertie Offer Guarantee (DA-IOG). This ensures that the participant recovers the costs of supplying energy in real-time that was committed day-ahead. The DA-IOG is similar to the DA-PCG except that it does not include start-up costs or operating reserve components.

The DA-IOG is calculated as shown in Figure 18.

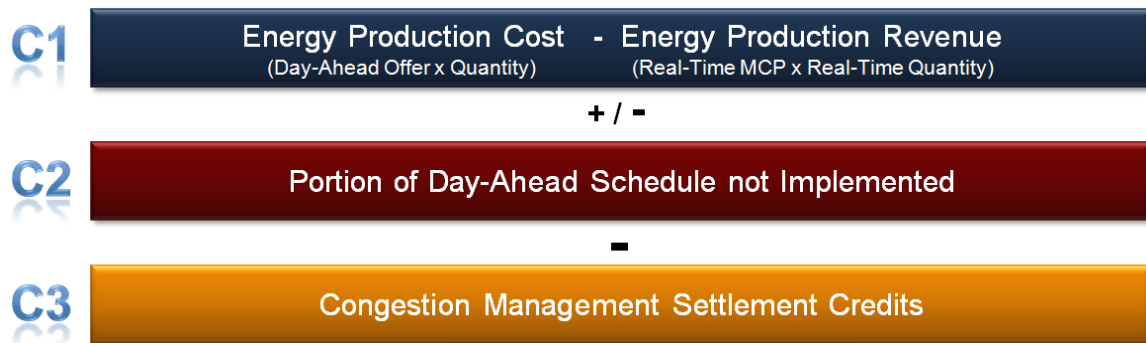

Figure 18: DA-IOG Calculation

Day-ahead scheduled imports and exports from the same participant are considered to be implied day-ahead linked wheels for settlement purposes. Import transactions that are part of an implied linked wheel do not receive IOG payments.

To determine if an import receives a DA-IOG, the calculated DA-IOG for each day-ahead import is stacked from lowest to highest IOG rate (\$/MW). The quantity of day-ahead scheduled exports for the participant is then overlaid. If the total export MW is greater than 50% of a day-ahead import transaction, the import is not eligible for a DA-IOG as it is considered to be part of a linked wheel. The transaction may, however, qualify for a Real-Time Intertie Offer Guarantee (RT-IOG).

The DA-IOG is highlighted by the following features:

- We use an IOG rate rather than total IOG dollars per transaction during calculation of the offset process.
- We determine if an import transaction scheduled day-ahead was part of a day-ahead implied wheel to determine whether it is eligible for a DA-IOG.

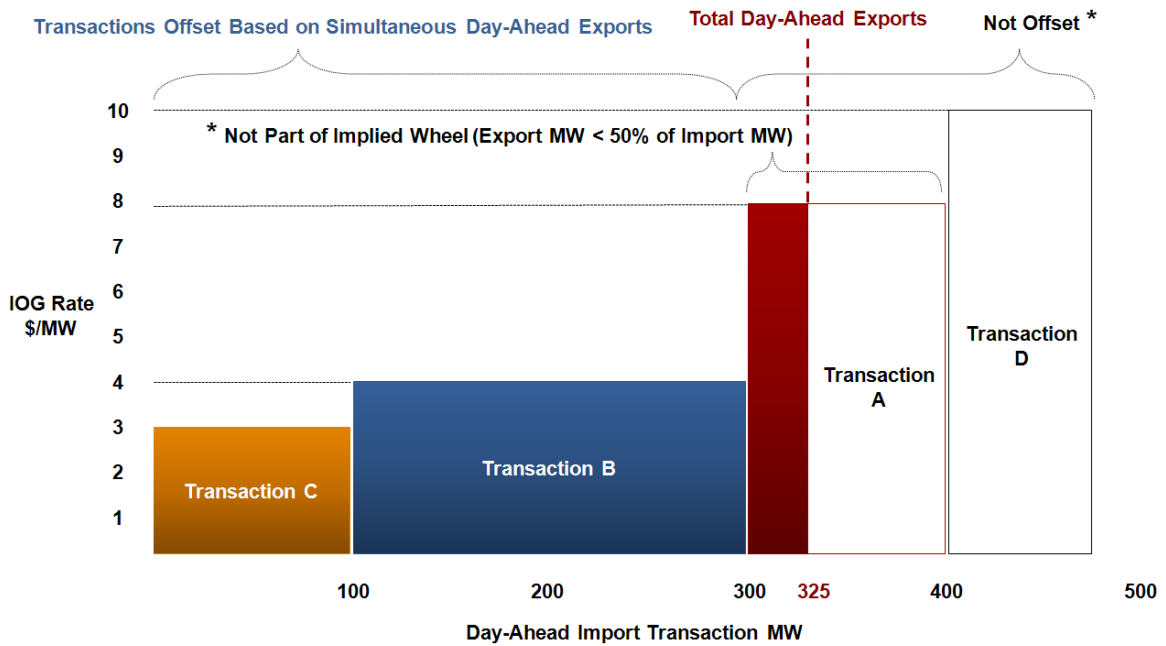

Figure 19: IOG Rate vs. Day-Ahead Import Transaction

In real-time, simultaneous imports and exports from the same participant are considered implied wheels, regardless of whether or not the import was scheduled day-ahead. Assume that all of the transactions shown in Figure 19 flow in real-time. The RT-IOG offset process stacks all import transactions from lowest to highest IOG rate (\$/MW). The transactions that were offset based on simultaneous day-ahead exports (i.e., transactions B and C) are stacked using their RT- IOG rate. The transactions that were not offset (i.e., transactions A and D) based on an implied day-ahead wheel are stacked using the higher of their DA-IOG or RT-IOG rates (Figure 20). The corresponding quantity of exports from that participant is overlaid and the lowest value IOGs are clawed back, up to a maximum of the total export quantity.

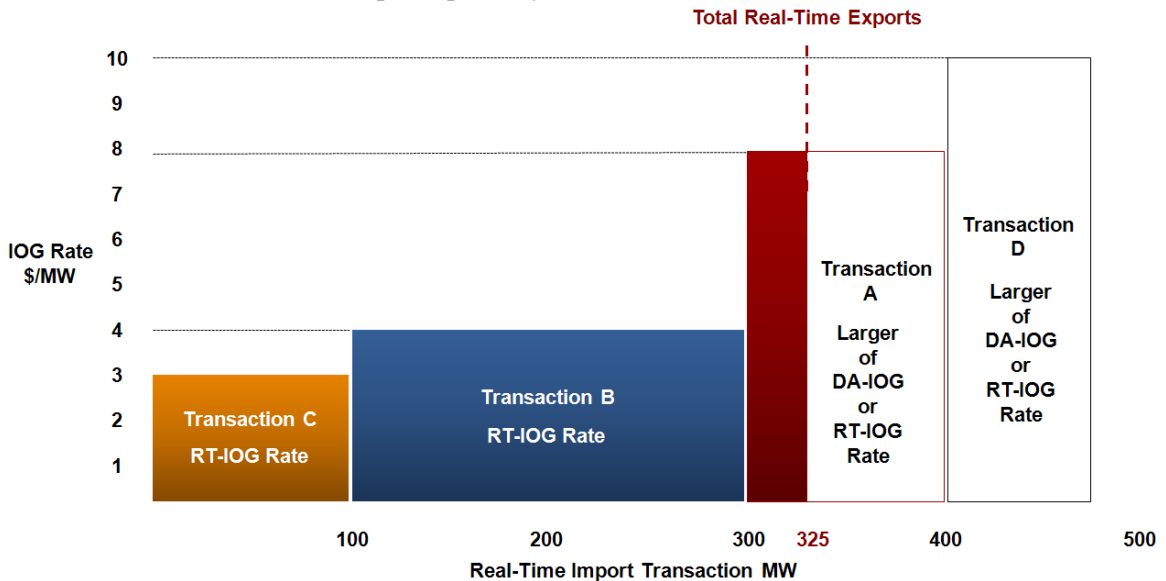

Figure 20: IOG Rate vs. Real-Time Import Transaction

Day-Ahead Import Failure Charge (DA-IFC)

Imports scheduled day-ahead that fail to flow in real-time are subject to an automatic failure charge based on the quantity that didn't flow multiplied by a price differential.

Failures outside the participant's control are exempt from the charge. In some cases the exemption is conditional upon a real-time offer price test which consists of the following two parts:

- The real-time import schedule must be less than the day-ahead import schedule.
- The first lamination of the price/quantity pairs of the real-time offer must be offered at *negative* Maximum Market Clearing Price (MMCP).

For more detailed information, refer to IESO_MAN_0080 - *Market Manual Part 9.5: Settlement for the Day-Ahead Commitment Process*.

The import failure charge uses the hour-ahead pre-dispatch price in the price differential calculation (refer to Figure 21). The charge reflects the quantity that failed to flow multiplied by its impact on the market.

The degree of impact is based on the lesser of the price difference between the day-ahead offer and the following:

- The hour-ahead pre-dispatch offer.
- The hour-ahead pre-dispatch price.

The DA-IFC is the lesser of:

C1

$$\frac{(\text{Pre-Dispatch } \textit{Ontario} \text{ Price} - \text{Day-Ahead Offer Price})}{X} \times (\text{Day-Ahead Constrained Schedule} - \text{Pre-Dispatch Constrained Schedule})$$

Or:

C2

$$\frac{(\text{Pre-Dispatch Offer Price} - \text{Day-Ahead Offer Price})}{X} \times (\text{Day-Ahead Constrained Schedule} - \text{Pre-Dispatch Constrained Schedule})$$

Or:

C3

$$\frac{(\text{Pre-Dispatch } \textit{Ontario} \text{ Price})}{X} \times (\text{Day-Ahead Constrained Schedule} - \text{Pre-Dispatch Constrained Schedule})$$

Figure 21: DA-IFC Calculation

Assume that the following conditions occur:

- Day-ahead import offer = 100 MW at \$70.
- Pre-dispatch import offer = 100 MW at \$80.
- The hour-ahead pre-dispatch Ontario price = \$72.
- Day-ahead constrained schedule = 100 MW.
- The hour-ahead pre-dispatch constrained schedule = 0 MW with an *AUTO* reason code.

Using this example, the DA-IFC is calculated as shown in Table 4 based on the lowest value of the three components from Figure 21:

Component	DA-IFC Calculation	DA-IFC Result
C1	$(\$72 - \$70) \times (100\text{MW} - 0\text{MW}) = \200	\$200
C2	$(\$80 - \$70) \times (100\text{MW} - 0\text{MW}) = \1000	
C3	$(\$72) \times (100\text{MW} - 0\text{MW}) = \7200	

Table 4: DA-IFC Example

Based on this example, the participant owes a Day-Ahead Import Failure Charge (DA-IFC) of \$200.

Day-Ahead Export Failure Charge (DA-EFC)

The DACP allows day-ahead export scheduling. Exports that fail to flow in real-time can affect reliability and the markets in the same way as failed imports. As a result, we implement an export failure charge with the DACP (refer to Figure 22).

Failures outside the participant's control are exempt from the charge. In some cases the exemption is conditional upon a real-time bid price test which consists of the following two parts:

- The real-time export schedule must be less than the day-ahead export schedule.
- The first lamination of the price/quantity pairs of the real-time bid must be offered at *positive* Maximum Market Clearing Price (MMCP).

For more detailed information, refer to IESO_MAN_0080 - *Market Manual Part 9.5: Settlement for the Day-Ahead Commitment Process*.

The DA-EFC is the lesser of:

C1

$$\frac{(\text{Day-Ahead Bid Price} - \text{Pre-Dispatch Ontario Price})}{(\text{Day-Ahead Constrained Schedule} - \text{Pre-Dispatch Constrained Schedule})}$$

Or:

C2

$$\frac{(\text{Day-Ahead Bid Price} - \text{Pre-Dispatch Bid Price})}{(\text{Day-Ahead Constrained Schedule} - \text{Pre-Dispatch Constrained Schedule})}$$

Or:

C3

$$\frac{(\text{Day-Ahead Bid Price})}{(\text{Day-Ahead Constrained Schedule} - \text{Pre-Dispatch Constrained Schedule})}$$

Figure 22: DA-EFC Calculation

Assume that the following conditions occur:

- Day-ahead export bid = 100 MW at \$50.
- Pre-dispatch export bid = 100 MW at \$40.
- The hour-ahead pre-dispatch Ontario price = \$48.
- Day-ahead constrained schedule = 100 MW.
- The hour-ahead pre-dispatch constrained schedule = 0 MW with an *AUTO* reason code.

Using this example, the DA-EFC is calculated as shown in Table based on the lowest value of the three components from Figure 22:

Component	DA-EFC Calculation	DA-EFC Result
C1	$(\$50 - \$48) \times (100\text{MW} - 0\text{MW}) = \200	\$200
C2	$(\$50 - \$40) \times (100\text{MW} - 0\text{MW}) = \1000	
C3	$(\$50) \times (100\text{MW} - 0\text{MW}) = \5000	

Table 5: DA-EFC Example

Based on this example, the participant owes a Day-Ahead Export Failure Charge (DA-EFC) of \$200.

Day-Ahead Linked Wheel Failure Charge (DA-LWFC)

Linked wheels scheduled day-ahead that fail to flow in real-time are subject to a failure charge based on the indirect impact on the Ontario energy price (refer to Figure 23). A

linked wheel scheduled day-ahead can displace other inertie transactions (i.e., the wheel could create congestion that limits the scheduling of other imports or exports). The failure charge is based on the price spread between the two affected inertie zones.

A linked wheel attracts a failure charge if both of the following conditions occur:

- The pre-dispatch constrained schedule is less than the day-ahead constrained schedule.
- The day-ahead price spread is higher than the pre-dispatch price spread, where price spread equals import leg (source) inertie zone price – export leg (sink) inertie zone price.

Failures outside the participant's control are exempt from the charge.

Real-time failure charges for the import MWh failure between day-ahead and pre-dispatch are calculated and compared to what the day-ahead linked wheel failure charge would be, and the lesser of the two is charged. This ensures that the day-ahead linked wheel failure charge is never greater than what the real-time failure charges were to be; thereby removing any incentive that would delay a linked wheel failure to real-time.

The DA-LWFC is the lesser of:

C1

$$\frac{(\text{Day-Ahead Shadow Price Spread} - \text{Pre-Dispatch Shadow Price Spread})}{(\text{Day-Ahead Constrained Schedule} - \text{Pre-Dispatch Constrained Schedule})}$$

Or:

C2

$$\begin{aligned} & \text{Real-Time Export Failure Charge for} \\ & (\text{DA Export Constrained Schedule} - \text{PD Export Constrained Schedule}) \\ & + \\ & \text{Real-Time Import Failure Charge for} \\ & (\text{DA Import Constrained Schedule} - \text{PD Import Constrained Schedule}) \end{aligned}$$

Figure 23: DA-LWFC Calculation

For more detailed information, refer to IESO_MAN_0080 - *Market Manual Part 9.5: Settlement for the Day-Ahead Commitment Process*.

9. Publishing and Reporting

Overview

Reporting refers to the creation of documents related to the operation of the IESO-administered markets. *Publishing* refers to the preparation of public documents made available on the IESO web site. DACP-related reports are explained below.

System Status Reports (SSR)

The System Status Report (SSR) published at 9:00 (before the dispatch data submission window closes at 10:00 EST) helps market participants make market and operational decisions.

Pre-Dispatch Reports

Pre-dispatch runs beginning between 15:07 and 23:07 publish data for the remaining hours of the current day and all hours of the next day.

Public Reports

These reports can be used by participants as a resource for making their day-ahead business decisions.

- **Day-Ahead Adequacy** - This report provides a summary of any projected shortfall or surplus of energy for the next day.
- **Day-Ahead Shadow Prices** - This report contains *shadow prices* for energy and operating reserve at selected nodes internal to Ontario and at the interties as calculated by the DACE.
- **Day-Ahead Area Operating Reserve Shortfalls** - This report contains any *operating reserve* shortfalls in each hour, by dispatch area, for the day ahead as calculated by the DACE.
- **Day-Ahead Area Reserve Constraints** - This report contains hourly maximum and minimum constraints for the *area reserve* regions used as inputs for the DACE. The report indicates regions where reserve supply may be an issue.
- **Day-Ahead Constrained Totals** - This report contains hourly MW totals (i.e., total energy, total losses, total load, total dispatchable load and total operating reserve).
- **Day-Ahead Intertie Scheduling Limits** - This report contains hourly *intertie scheduling limits*.
- **Day-Ahead Security Constraints** - This report contains binding *security constraints* as determined by the DACE. The report may help a participant understand why a particular resource received the schedule that it did.

Market Participant Confidential Reports

- **Day-Ahead Check Source / ADE** - This is one of two reports that comprise the Schedule of Record (SOR). The report provides the market participant with a

confirmation of the dispatch data submission used for a resource, included in the DACP SOR. This dispatch data forms the resource's ADE.

- **Day-Ahead Scheduled Energy** - This is one of two reports that comprise the SOR. The report provides energy and operating reserve schedules for each of a participant's resources for each hour of the next day.
- **Day-Ahead Commitments** - This report provides a list of a market participant's resources that have been committed for the DA-PCG. The report is a confirmation that PCG-eligible resources receiving a schedule in the SOR have been constrained to at least their MLP for their MGBRT in our systems for the next day.
- **Valid Bid Report** – This report is an existing query, available to market participants through the Energy Market Graphical User Interface Workspace, for viewing the most recent, valid, submitted dispatch data. The query is revised to allow market participants to see submitted three-part offers.
- **Daily Generator Data Report** – *Not quick start* dispatchable generation facilities receive a report that provides the DGD used in the DACP. The report provides a confirmation of the DGD that was used by the DACE when determining the next day's schedules. This report is available after 10:00 EST of the DACP day.
- **PSU DGD Computed Values Report** - This report provides the values used by the DACE for PSUs, as of 10:00. These values are computed from the market participant DGD submission for physical units.

Day-Ahead Schedule of Record (SOR)

The SOR is published after the successful completion of the DACP. The SOR is made up of two sets of private reports—the Day-Ahead Scheduled Energy Reports and the Day-Ahead Check/Source ADE Reports. If either of these reports fails to publish, the DACP is declared a failure for that day. On a successful day, the SOR is always published by 15:00 and is always based on the last set of published results.

DACP Failure Notification

A notification of *DACP Failed* will be sent in the event that no DACE results have been produced, or the results cannot be published to the market participants. If invalid results are inadvertently published as the SOR, a DACP failure will also be declared. Publication of the SOR and notification of DACP failure both serve as notice of completion of DACP for the day.

10. Additional Information

For additional information, please refer to the resources listed below.

- For more detailed information relating to the DACP registration process, refer to [IESO MAN 0076](#) - *Market Manual Part 9.1: Submitting Registration Data for the Day-Ahead Commitment Process*.
- The forms relating to the DACP registration process can be found on the IESO web site via the following links:
 - [IMO_FORM_1552 – Real-Time Generation Cost Guarantee and DA-PCG Form](#)
 - [IMO FORM 1181 – Facility Profile](#)
 - [IESO FORM 1702 – Combined Cycle Plant Form](#)
 - [IMO-FORM-1004 - Generation Facilities](#)
 - [IESO-FORM-1721 - Implementation of Three Part Offers](#)
 - The *Introduction to Ontario's Physical Markets* workbook is available on our [Training](#) web pages.
 - Training's [DACP recorded presentations](#)
 - For other DACP-related information, please refer to the [DACP web pages](#).
 - The *Energy Market Graphical User Interface Workspace Guide* can be found [here](#).

List of Acronyms

ADE – Availability Declaration Envelope

API – Application Programmer Interface

CCP – Combined Cycle Plant

CT – Combustion Turbine

DACE – Day-Ahead Calculation Engine

DACP - Day-Ahead Commitment Process

DA-EFC – Day-Ahead Export Failure Charge

DA-IFC – Day-Ahead Import Failure Charge

DA-IOG – Day-Ahead Intertie Offer Guarantee

DA-LWFC – Day-Ahead Linked Wheel Failure Charge

DA-PCG – Day-Ahead Production Cost Guarantee

DCHD – Daily Cascading Hydroelectric Dependency

DEL – Daily Energy Limit

DGD – Daily Generator Data

EELR – Eligible Energy Limited Resource

ELR – Energy Limited Resource

EOD – Expedited Operational Data

ETD – Elapsed Time to Dispatch

IOG – Intertie Offer Guarantee

MCP – Market Clearing Price

MGBDT - Minimum Generation Block Down-Time

MGBRT – Minimum Generation Block Run-Time

MLP – Minimum Loading Point

MMCP – Maximum Market Clearing Price

MRT – Minimum Run-Time

PSU – Pseudo Unit

RMP – Registered Market Participant

RTD – Registered Technical Data

RTEM - Real-Time Energy Market

RT-GCG – Real-Time Generation Cost Guarantee

RT-IOG – Real-Time Intertie Offer Guarantee

SOR – Schedule of Record

SSR – System Status Report

ST – Steam Turbine

TSG – Transitional Scheduling Generator

Glossary of Terms

Availability Declaration Envelope (ADE) - The hourly capacity offered day-ahead for dispatchable generation facilities, or the hourly load bid as dispatchable day-ahead for dispatchable loads (the ADE for the dispatch day).

Combined Cycle Plant (CCP) – A generation facility that is composed of one Steam Turbine (ST) and a collection of one or more associated Combustion Turbines (CT) that have a gas-to-steam relationship between the outputs of their respective physical units.

Daily Cascading Hydroelectric Dependency (DCHD) - A dispatchable hydroelectric generation facility has a DCHD if the facility has a *minimum hydraulic time lag* (i.e., the minimum amount of time that it takes water to flow from one hydroelectric facility to another) of less than 24 hours to or from an adjacent cascading hydroelectric generation facility that is controlled by the same Registered Market Participant (RMP).

Daily Energy Limit (DEL) - Represents the maximum amount of energy that can be scheduled at a specified hydroelectric generation facility for a given day.

Daily Generator Data (DGD) - The registered generation facility data that can be updated on a daily basis in day-ahead only.

Day-Ahead Production Cost Guarantee (DA-PCG) - A settlement amount that guarantees cost recovery for eligible dispatchable generation facilities when dispatched to produce energy in the real-time market, and where real-time revenue is insufficient to cover as-offered costs to produce schedules as committed day-ahead.

Dispatch Data – Defined by the market rules as the offers, bids, self-schedules, and estimates of intermittent generation required to be submitted to the IESO; this information is used to determine physical operations, physical market prices, capacity reserve prices, and capacity reserve quantities for the capacity reserve market if activated by the IESO Board.

Duct Firing Capacity - The capacity available from the duct firing of a physical steam turbine. For registration purposes, a single value of duct firing capacity is provided and captured for a steam turbine resource associated with a Combined Cycle Plant (CCP) that has indicated the desire to use Pseudo Unit (PSU) modeling. The value must reflect the technical capability of the generation unit.

Elapsed Time to Dispatch (ETD) - The minimum amount of time, in minutes, between the point at which a generation unit initiates its start-up sequence and the point at which it becomes dispatchable by reaching its Minimum Loading Point (MLP). For fossil fired generation units, this is based on a hot start.

Eligible Energy Limited Resource (EELR) - An Energy Limited Resource (ELR) that is a cascade hydroelectric generation facility with a minimum hydraulic time lag to adjacent (upstream or downstream) hydroelectric generation facilities of less than 24 hours, and where the upstream hydroelectric generation facility is operated by the same Registered Market Participant (RMP).

Maximum Number of Starts Per Day - The number of times a generation unit can be started within a dispatch day - formerly part of Expedited Operational Data (EOD).

Minimum Generation Block Down-Time (MGBDT) - The minimum number of hours (specified by the market participant) required between the time a generation facility is last at its Minimum Loading Point (MLP) before de-synchronization, and the time the generation facility reaches its MLP again after synchronization.

Minimum Generation Block Run-Time (MGBRT) - Defined by the market rules as the number of hours, specified by the market participant, that a generation facility must be operating at Minimum Loading Point (MLP) in accordance with the technical requirements of the facility.

MGBRT Limit - Calculated as a generation facility's registered Minimum Generation Block Run-Time (MGBRT) multiplied by the *MGBRT tolerance* (i.e., a static percentage, greater than or equal to 100%, defining the tolerance applied to the daily generator data MGBRT above the registered MGBRT). This value cannot exceed 24 hours.

Minimum Loading Point (MLP) - Defined as the minimum output of energy specified by the market participant that can be produced by a generation facility under stable conditions without ignition support.

MLP Limit - Calculated as a generation facility's registered Minimum Loading Point (MLP) multiplied by the *MLP tolerance* (i.e., a static percentage, greater than or equal to 100%, defining the tolerance applied to the daily generator data MLP above the registered MLP). This value cannot exceed the resource's maximum generator capacity.

Minimum Run-Time (MRT) - Defined by the market rules as the number of hours required for the generation facility to ramp from a cold start to Minimum Loading Point (MLP) plus Minimum Generation Block Run-Time (MGBRT), specified by the market participant, in accordance with the technical requirements of the facility.

PCG-Eligible Facility - A facility that is not a quick start facility, has a Minimum Loading Point (MLP) greater than zero, and has a Minimum Generation Block Run-Time (MGBRT) greater than one hour. This facility needs to initiate a start-up sequence greater than one hour in advance of the hour in which it first receives a schedule in order to respond to a dispatch associated with its constrained schedule.

Pseudo Unit (PSU) - A Combined Cycle Plant (CCP) that is modeled based on a gas-to-steam relationship between physical units. A PSU is comprised of one Combustion Turbine (CT) and a share of one Steam Turbine (ST) at the same CCP.

Quick Start Facility - Defined by the market rules as a generation facility whose electrical energy output can be provided to the IESO-controlled grid within 5 minutes of the IESO's request, and is provided by equipment not synchronized to the IESO-controlled grid when the request to start providing energy is made (in keeping with existing IESO market manuals, the term *not quick start* facility is used in this document to refer to a generation facility that *does not* meet the definition of a *quick start* facility).

Real-Time Generation Cost Guarantee (RT-GCG) - Some forms of generation, primarily fossil, can take anywhere from two to sixteen hours to start and synchronize to the grid. During this period, they incur significant start-up costs. They might then be unable to make sufficient market revenues to cover these costs. The RT-GCG removes this concern by covering certain costs should market revenues fall short. In this way, the program ensures that more generation is available on-line to respond to disturbances.

Shadow Prices - The price of energy at every injection and withdrawal point; calculated by the constrained mode, which considers the effects of ramp rates, losses, and transmission limits (shadow prices are not used for settlement).

Steam Turbine Percentage Share of a PSU - The amount of steam turbine capacity associated with each Pseudo Unit (PSU), expressed as a percentage. The values are captured only when the market participant intends to use PSU modeling and must reflect the technical capability of the generation unit.