



CONNECTION ASSESSMENT & APPROVAL PROCESS

PRELIMINARY ASSESSMENT REPORT

***For the connection of the Five Nations Energy Inc. Project
to the 115kV circuit C6R: Abitibi Canyon GS to Moosonee DS***

CAA N^o. 2000-015

Long Term Forecasts & Assessments Department

Date: 22nd November 2000

Revised: 13th February 2001

FIVE NATIONS ENERGY PROJECT AT MOOSONEE

1. Details of the Proposed Connection

Five Nations Energy Inc. is proposing to construct a new 270km 115kV transmission line and to connect it to the existing 115kV circuit C6R at Moosonee DS. The new transmission line is to supply local area loads at Fort Albany, Kashechewan and Attawapiskat that are currently supplied by diesel generators.

Diagram 1 shows the proposed arrangement.

The radial 115kV circuit C6R is terminated on to the Hydro One system at Abitibi Canyon GS, which in turn is radially connected to the main 115kV system at Hunta SS. Circuit C6R consists of a 35.4km section to Otter Rapids GS and a further 144km section from Otter Rapids GS to Moosonee DS. Circuit C6R is not normally connected to the Otter Rapids busbar.

Voltage control for the 115kV supply to Moosonee DS has traditionally been provided from one or both of the generators connected to the 115kV busbar at Abitibi Canyon GS. It has been assumed that this practice will continue.

The new 115kV transmission line is to be terminated, via two series-connected circuit breakers, at the New Moosonee Substation which is located directly adjacent to the existing Moosonee DS. The new Substation is to be tapped on to the existing 115kV circuit C6R close to Moosonee DS.

The Five Nations 115kV transmission line is to comprise three sections, with lengths of 159km (to Fort Albany), 11km (to Kashechewan) and 100km (to Attawapiskat) respectively. The final section is to be switched via a 115kV circuit breaker at Kashechewan.

Voltage control is to be provided via a total of four 115kV shunt reactors located at Moosonee (one 6.5MVAR reactor), Fort Albany (two 3.4MVAR reactors) and at Attawapiskat (one 2.5MVAR reactor). Each reactor is to be switched by a dedicated circuit-switcher. While the single step-down transformers that are to be installed at each supply point will only be equipped with off-load tap-changers, additional under-load voltage control is to be provided via LV voltage regulators located at each supply substation. The tap-changer range for the step-down transformers is to be +2.5% (141.5kV) to -7.5% (127.7kV) in 4 steps. The voltage regulators are to have a range of $\pm 10\%$.

The existing diesel generators are not to be connected to the new transmission line and will not be operated in parallel with the IMO-controlled grid.

The new facilities are to be staged, with the first section scheduled to be in-service in July 2001.

2. Impact on Reliability

In order to assess the impact of the new transmission line on the supply to the existing load at Moosonee DS, various operating situations were considered:

2.1 Breaker Failure Condition

The design proposed by Five Nations Energy Inc. does not include facilities to provide a transfer trip capability to the 115kV circuit breakers at Abitibi Canyon GS in the event of a breaker failure condition at the New Moosonee Substation. In order to address a breaker failure condition, Five Nations Energy Inc. has therefore proposed an arrangement with two, series-connected circuit breakers at the New Moosonee Substation.

In the event of a fault on the new 115kV transmission line, trip signals are to be sent to both circuit breakers simultaneously to ensure rapid fault clearance if one breaker should fail to operate.

In addition, since a shunt reactor is to be connected between the two circuit breakers at the New Moosonee Substation, a trip signal is to be sent to the circuit switcher associated with the shunt reactor (at the same time as the trip signals are sent to the two circuit breakers). This action is required to ensure that the reactor does not remain connected to circuit C6R in the event of a breaker failure condition involving circuit breaker CB1.

2.2 Busbar Fault at the New Moosonee Substation

A busbar fault at the New Moosonee Substation, involving any of the equipment connected between the two circuit breakers, would only have circuit breaker CB1 available for fault isolation. To address a possible breaker failure condition involving circuit breaker CB1, a signal to open the disconnect switch associated with circuit breaker CB1 is to be sent simultaneously with the trip signal to the circuit breaker. For this reason the disconnect switch must be motorised.

2.3 Response of the circuit breakers to low gas pressure.

Five Nations Energy Inc. has confirmed that the circuit breakers at the New Moosonee Substation will 'lock-out' in the *closed* position when a low gas pressure condition is detected.

In the event that either circuit breaker were to 'lock-out', the breaker 'redundancy' that is required to address a subsequent breaker failure condition, should a contingency occur, would no longer be available.

The IMO has discussed this matter with Five Nations Energy Inc. and agreed that the following responses will be satisfactory to the IMO:

- In the event that an alarm is received from either of the circuit breakers at the New Moosonee Substation, the 115kV transmission line would be allowed to remain in-service, but the circuit breaker would be expected to receive urgent attention.
- In the event that either of the circuit breakers at the New Moosonee Substation 'locks out', the companion circuit breaker must be tripped immediately, and the line would then be isolated via the motorised disconnect switch. In the event that the companion breaker fails to operate, circuit C6R would be isolated from the system at Abitibi Canyon GS by the System Operators upon receipt of the alarm. The Five Nations 115kV line would then be isolated via the motorised disconnect at the New Moosonee Substation. Circuit C6R would then be returned to service, restoring the supply to Moosonee DS.

2.4 IMO's Requirements

Subject to the implementation of the following IMO requirements, the 115kV transmission facilities proposed by Five Nations Energy Inc. are expected to have only a minimal impact on the reliability of supply to the existing load at Moosonee DS:

- i. The disconnect switch associated with circuit breaker CB1 at the New Moosonee Substation must be motorised.
- ii. For a line fault, simultaneous trip signals are to be sent to circuit breakers CB1 & CB2 and to the circuit switcher associated with the shunt reactor at the New Moosonee Substation.
- iii. For a busbar fault at the New Moosonee Substation, involving any of the equipment connected between the two circuit breakers, circuit breaker CB1 is to be tripped and simultaneously a signal is to be sent to open the motorised disconnect switch.
- iv. The implementation of the responses, as detailed in 2.3 above, to alarms or ‘lock-out’ conditions involving either of the circuit breakers at the New Moosonee Substation.

3. Voltage Control

At 138kV, the line charging requirements of the new 270km line will be approximately 19MVAR. Five Nations Energy is proposing to install 138kV shunt reactors with a total capacity of 15.8MVAR. Together with the transformer losses, this should be sufficient to provide full compensation for the line charging MVARs.

In order to maintain reasonably stable voltages at each of the supply points under different loading patterns, Five Nations Energy is proposing to vary the number of shunt reactors that are in-service. While we have some reservations regarding the performance of the circuit-switchers that are to be used for switching the reactors, particularly under adverse temperature conditions, the addition of an under/over voltage tripping feature at Moosonee DS would ensure that their performance does not have a detrimental impact on the reliability of the IMO-controlled grid. In the event that the voltage at Moosonee DS moves outside the acceptable range, this required feature would initiate automatic tripping of the two circuit breakers at the New Moosonee Substation to isolate the new transmission facilities from the existing system.

Based on the fault levels provided by Hydro One and quoted below, the switching of the shunt reactors should not violate Hydro One’s criterion of 4% for the maximum voltage change that is permissible at Moosonee DS.

<i>Fault Levels on the Existing 115kV System Values are for a Pre-fault Voltage of 138kV</i>				
Case	Conditions	Abitibi Canyon GS 115kV	Otter Rapids GS 115kV	Moosonee DS
1	<i>Normal Maximum Condition</i> Abitibi Canyon units G2 & G3 in-service Otter Rapids units G1 & G2 connected to 230kV system	1167MVA	555MVA	149MVA
2	<i>Minimum Condition</i> No Abitibi Canyon units in-service Otter Rapids units G1 & G2 connected to 230kV system	827MVA	463MVA	142MVA
3	<i>Maximum Possible Condition</i> Abitibi Canyon units G2 & G3 in-service Otter Rapids units G1 & G2 connected to 115kV system	1560MVA	1174MVA	174MVA

Our preference would have been for a scheme using low voltage switching of capacitor banks to compensate for changes in load so as to minimise the amount of switching required of the 115kV shunt reactors. However, Hydro One’s analysis has shown that adequate voltage control is expected to be achievable with the arrangement as proposed.

4. Load to be Supplied

The following table summarises the loads that have been forecast for the next decade.

Base Load Forecast (with high and low estimates)

<i>Year</i>		<i>2001</i>	<i>2002</i>	<i>2003</i>	<i>2004</i>	<i>2005</i>	<i>2006</i>	<i>2007</i>	<i>2008</i>	<i>2009</i>	<i>2010</i>
Fort Albany & Kashechewan	MW	2.8	3.2	3.4	3.6	3.8	4.1	4.3	4.5	4.8	5.0
Attawapiskat	MW	1.7	2.0	2.1	2.3	2.4	2.6	2.7	2.9	3.0	3.2
Total (base)	MW	4.5	5.1	5.5	5.9	6.3	6.6	7.0	7.4	7.8	8.2
<i>Total (low)</i>	MW	4.0	4.4	4.7	4.9	5.2	5.5	5.8	6.1	6.4	6.7
<i>Total (high)</i>	MW	4.8	5.5	6.0	6.5	7.0	7.5	8.0	8.6	9.1	9.7

5. Hydro One's Studies

In addition to the voltage profile studies on the Five Nations System, Hydro One has completed studies to examine the impact of the proposed connection and the new load on the existing system. Their studies have confirmed that the existing transmission facilities will be able to supply the forecast load, together with the load that is expected at Moosonee DS during the 10-year period to 2010.

6. Metering

In accordance with the IMO Metering Procedure, a Single Line Diagram of the proposed metering arrangement should be submitted for review to ensure that it conforms to IMO requirements.

Subject to this review, it is expected that Five Nations Energy Inc.'s proposal to install low voltage metering at each of the three supply points would meet the IMO's metering criteria.

7. System Impact Assessment

This Preliminary Assessment has concluded that no further analysis is required for this Project and it is therefore recommended that the System Impact assessment be foregone.

8. Notification of Approval of the Connection Proposal

Based on the results of this Assessment, and subject to full implementations of the IMO's requirements, it is recommended that this Project should receive a *Notification of Approval of the Connection Proposal*.

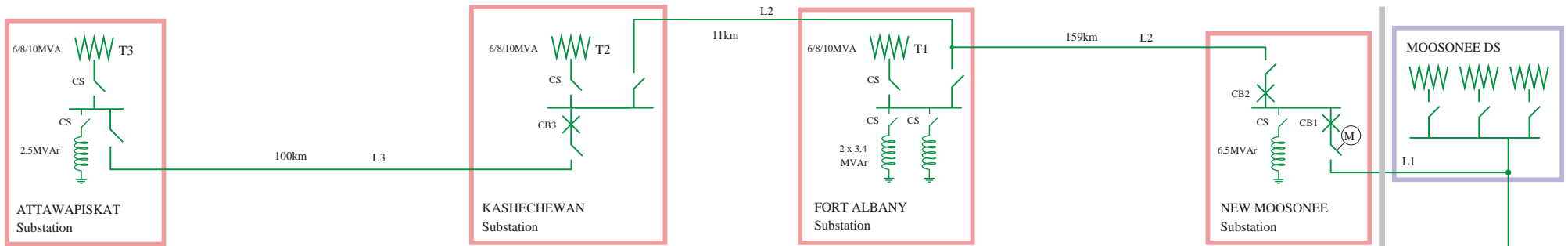

- CS Circuit-Switcher
- CB Circuit Breaker
- (M) Motorised

Line Construction: 138kV single-circuit line, equipped with 211.6kmil ACSR conductors and rated at 650kV BIL

FIVE NATIONS Inc. HYDRO ONE

FIVE NATION Inc. PROJECT
New 270km 115kV Line & Associated Facilities

