

# **CONNECTION ASSESSMENT & APPROVAL PROCESS**

## **Preliminary Assessment Report For Weyerhaeuser Company Kenora Mill Project**

*CAA ID 2000-019*

Final Report

Long Term Forecasts & Assessments Department  
December 5, 2001

## **Preliminary Assessment Report**

Weyerhaeuser Company – Kenora Mill Project

### **Acknowledgement**

The IMO wished to acknowledge the assistance of Hydro One in completing this assessment.

### **Disclaimers**

#### **IMO**

This report has been prepared solely for the purpose of assessing, on a preliminary basis, whether the connection applicant's proposed connection with the IMO-controlled grid would have an adverse impact on the reliability of the integrated power system and whether a System Impact Assessment of the proposed connection should be conducted under Chapter 4, section 6 of the *Market Rules*. This report has not been prepared for any other purpose and should not be used or relied upon by any person for another purpose. This report has been prepared solely for use by the connection applicant, Hydro One and the IMO in accordance with Chapter 4, section 6 of the *Market Rules*. The IMO assumes no responsibility to any third party for any use which it makes of this report. Any liability which the IMO may have to the connection applicant in respect of this report is governed by Chapter 1, section 13 of the *Market Rules*. In the event that the IMO provides a draft of this report to the connection applicant, you must be aware that the IMO may revise drafts of this report at any time in its sole discretion without notice to you. Although the IMO will use its best efforts to advise you of any such changes, it is the responsibility of the connection applicant to ensure that it is using the most recent version of this report.

#### **Hydro One**

The results reported in this preliminary feasibility study are based on the information available to Hydro One Networks Inc., at the time of the study, suitable for a preliminary assessment of a new generation or load connection proposal.

The short circuit and thermal loading levels have been computed based on the information provided by the connection proponent at the time of the study. These levels may be higher or lower if the connection information changes as a result of, but not limited to, subsequent design modifications or when more accurate test measurement data is available.

This study does not assess the short circuit or thermal loading impact of the proposed connection on facilities owned by other load and generation (including OPGI) customers.

In this preliminary feasibility study, short circuit adequacy is assessed only for Hydro One Networks Inc. breakers and does not include other Hydro One Networks Inc. facilities. The short circuit results are only for the purpose of assessing the capabilities of existing Hydro One Networks Inc. breakers and identifying upgrades required to incorporate the proposed connection. These results should not be used in the design and engineering of new facilities for the proposed connection. The necessary data will be provided by Hydro One Networks Inc. and discussed with the connection proponent upon request.

The ampacity rating of Hydro One Networks Inc. facilities are established based on assumptions used in Hydro One Networks Inc. for power system planning studies. The actual ampacity ratings during operations may be determined in real-time and are based on actual system conditions, including ambient temperature, wind speed and facility loading, and may be higher or lower than those stated in this study.

The additional facilities or upgrades which are required to incorporate the proposed connection have been identified to the extent permitted by a preliminary assessment. Additional facility studies may be necessary to confirm constructability and the time required for construction. System impact or further studies at more advanced stages of the project development may identify additional facilities that need to be provided or that require upgrading.

## **Executive Summary**

This assessment examined the effect of the proposed Weyerhaeuser development of a new wood product plant on the reliability of the IMO controlled grid. This project was subject to an expedited Connection Assessment process and it is not required to undergo a System Impact Assessment.

## **Proposed Project**

The Weyerhaeuser Company proposes to connect a new wood product plant to the 115 kV single circuit line K7K. This circuit is owned by Hydro One Networks Inc. and connects Kenora TS to Rabbit Lake TS. The Weyerhaeuser proposal includes the installation of customer owned 115/13.8 kV transformation facilities required to supply the plant. Hydro One Networks Inc. will be providing the line tapping facilities to the 115 kV single circuit line, K7K.

It is presently estimated that the transformer substation will be energized by January 26, 2002 and the plant is expected to draw production load in July 2002. The initial load is estimated to be 3 MW with an ultimate power consumption of 16.5 MW.

## **Impact on System Reliability**

The studies performed as part of the Preliminary Assessment indicate that the new Weyerhaeuser load does not have an adverse impact on the local area reliability.

Study results indicate that the post-contingency voltage declines at Rabbit Lake TS and Kenora TS are acceptable and the new development does not influence the Kenora Area Inflow operating limit. Transient stability study results show no reduction the power transfer capability out of the Kenora Area.

The proposed transformer station and additional load do not have a significant impact on the system fault levels.

## **Requirement for Load Rejection Facilities**

Existing system operating practices for the Kenora area, require that certain loads be tripped under contingency situations in order to avoid the collapse of the area due to excessive voltage decline.

It is required that load rejection facilities be installed at Weyerhaeuser plant, which will ensure that the load is tripped for the loss of the 115 kV double circuit line K4W and K5W.

## **Conclusions and Recommendations**

This Preliminary Assessment has examined the impact of connecting the new 16.5 MW Weyerhaeuser Mill load on the 115 kV circuit K7K. The assessment concluded the following:

1. Under the connectivity arrangement that was proposed by the applicant, the new load cannot be supplied when the 115 kV circuit K7K is out of service.

2. The connection applicant has indicated that the new developments will be operated at 0.95 power factor and this is acceptable under the *Market Rules*.
3. The addition of the new supply point does not have an effect on the short circuit current in the area.
4. Because this load is under 20 MVA there is no requirement under the *Market Rules* for installation of monitoring facilities or voltage reduction facilities.
5. The new Weyerhaeuser load does not have an adverse impact on the post-contingency voltage decline at Rabbit Lake TS, or Kenora TS, and does not influence the Kenora Area Inflow operating limit.
6. The new Weyerhaeuser load does not have an adverse impact on the system transient stability because it does not reduce in any way the transfer capability of the system and does not limit the output of the local generation.
7. It is required that load rejection facilities be installed at Weyerhaeuser plant, which will ensure that the load is tripped for the loss of the 115 kV double circuit line K4W and K5W.

It is required that Weyerhaeuser provide the IMO with the following information as soon as it becomes available:

8. A confirmation that a underfrequency load shedding relay, which will have the capability of tripping up to 35% of the station load (12% at 59.3 Hz and additional 23% at 58.8 Hz) is to be installed. It is required that the connection applicant provide information on load distribution and the most likely operation of the plant prior to commissioning to enable the IMO to supply appropriate settings for the relay.

The Customer Connection Assessment carried out by Hydro One, concluded that the new proposed Weyerhaeuser connection does not impact the existing customers connected to the IMO-controlled grid.

## **Preliminary Assessment Report**

### **1.0 Project Description**

Weyerhaeuser Company is in the process of building a new wood product plant on a property adjacent to Kenora TS. The connection applicant has decided to install the 115/13.8 kV transformation facilities required to supply the plant, and have Hydro One provide the line tapping facilities to the K7K 115 kV single circuit line.

It is presently estimated that the transformer substation will be energized by January 26, 2002 and the plant is expected to draw production load in July 2002. The initial load is estimated to be 3 MW with an ultimate power consumption of 16.5 MW.

The new transformer station will be connected to the 115 kV circuit K7K that connects Kenora TS to Rabbit Lake TS. A diagram of the Kenora area and the location of the new load are shown in Figure 1.

This project was subject to an expedited CAA process, whereby an extended Preliminary Assessment was performed to address all the related concerns and a System Impact Assessment was not required.

### **2.0 Review of Connection Arrangement**

The proposed wood product plant shall be connected to the IMO controlled grid via a single 115/13.8 kV transformer rated at 20/26/33 MVA. The transformer is configured with a delta winding on the high side and a wye winding on the low voltage side. The wye winding is grounded through a reactor. Based on the single line diagram D.9935.E.30.03.001 provided by the connection applicant the transformer is separated from the transmission system via a HV SF6 circuit breaker and a motorized disconnection switch.

Voltage control is to be provided via on-load tap changers with a voltage range of  $\pm 12.1$  kV on a nominal voltage of 121 kV. The voltage control is to be achieved in 16 steps.

The connection applicant has proposed to connect its transformer to the 115 kV single circuit line K7K as indicated in Figure 2A. The exact location of the tap point is to be at a point adjacent to the K7K line disconnect 34-K7K, a point that is located between the disconnect switch and Rabbit Lake TS. This configuration provides a reduced of supply reliability because the power supply to the Weyerhaeuser operation is discontinued for all outages related to the 115 kV K7K circuit.

It was proposed by Hydro One that one additional disconnect switch be installed as shown in Figure 2B. This configuration would ensure continued supply of the customer load for K7K outage conditions. The connection applicant has decided, however, to keep the original connection arrangement that is shown in Figure 2A.

It should also be noted that the load will be tripped by configuration for faults on K7K line, T1 Kenora transformer and Kenore 230 kV P bus.

It can be concluded that:

The connection configuration proposed by Weyerhaeuser Company meets all the requirements of the *Market Rules*.

### 3.0 Underfrequency Load Shedding Requirements

The *Market Rules* (Chapter 5 section 10.4) require that each distributor and connected wholesale customer, in conjunction with the relevant transmitter, make arrangements to enable the automatic disconnection of under-frequency demand of up to 35% of its peak demand. To meet this requirement an underfrequency load shedding (UFLS) relay must be installed at the station on the low voltage bus. The single line diagram does not show the presence of the UFLS relay. The underfrequency load shedding relay will have the capability of tripping 12% of the station load at 59.3 Hz and an additional 23% at 58.8 Hz.

It is required that the connection applicant provide information on load distribution and the most likely operation of the plant prior to commissioning to enable the IMO to supply appropriate settings for the relay.

It is required that underfrequency load shedding facilities be provided to automatic disconnection of up to 35% of the peak demand. The connection applicant is to provide information on load distribution and the most likely operation of the plant prior to commissioning to enable the IMO to supply appropriate settings for the underfrequency relay.

### 4.0 Data Verification

The connection applicant has provided all the required technical information with their application as follows:

- The 115/13.8 kV transformer which is rated at 20/26/33 MVA has an impedance of 8% on 20 MVA base,
- The transformer winding configuration is delta on the high side and wye on the low side with the wye winding grounded through a 20 ohms, 400A reactor ,
- There are eight production lines connected to a 13.8 kV common bus,
- Six of the eight production lines operate at 600 V and each one is equipped with 450 kVar auto-switching power factor correction shunt capacitors,
- The two medium voltage production lines are equipped with approximately 1300 kVar shunt capacitors.

General industry standards require that, at 13.8 kV voltage level, the grounding reactor be about 1.25 ohms and have a continuous rating of 1000A and 15 s current rating of 6000A. It has been indicated by the connection applicant that the size of the transformer neutral reactor (20 ohms) was selected by design to allow the feeder ground fault backup relay to be very sensitive. Hydro One confirmed that due to the delta connection on the primary side, Hydro One does not make any contribution to the ground fault on the customers LV side and vice versa and therefore, it is up to the customer to select the size of the grounding resistor.

Hydro One requires that the customer submit a design package including their protection arrangement and protection philosophy before their connection to Hydro One system is approved. The protection design is to be reviewed by Hydro One P&C staff.

The Preliminary Assessment application indicates that the new load will be operated at 0.95 power factor. This load power factor performance meets the *Market Rules* requirement of Appendix 4.3, which states that the *connected wholesale customers* connected to the IMO-controlled grid shall operate at a power factor within the range of 0.9 lagging to 0.9 leading as measured at the *defined meter point* (which is the high side of the distribution transformer).

The rating of transformer station equipment was found to meet all applicable standards, with the exception of the proposed transformer grounding resistor which appears to be too large. A review of the proposed station protection will be carried out as part of the connection work.

The connection applicant has indicated that the new developments will be operated at 0.95 power factor.

## **5.0 Fault Level Assessment**

The proposed transformer station and additional load do not have a significant impact on the system fault levels. Studies carried out by Hydro One for similar proposals show that their contribution to single-line-to-ground fault or three phase fault currents is negligible.

## **6.0 Impact on System Reliability**

To assess the impact of the new load on reliability, two system scenarios were selected which represent limiting system operating conditions. The effect of incorporating the proposed development was measured for conditions of peak load in the Kenora 115 kV pocket and maximum power inflow into the area and conditions of maximum power outflow out of the area.

### **6.1 Description of Kenora Area Transmission**

The new Weyerhaeuser plant will be connected to the 115 kV single circuit line K7K which is part of the Kenora area 115 kV system. The Kenora Local Area is the 115 kV area bound by circuits K3D, K6F and the Kenora TS 230/115 kV. A single line diagram of the Kenora Area system is shown in Figure 1.

This system comprises of Rabbit Lake 115 kV transformer station and the following 115 kV single circuit lines:

- K4W and K5W connecting the Caribou Falls GS and Whitedog Falls GS to Rabbit Lake TS,
- K7K between Rabbit Lake TS and Kenora 115/230 kV transformer,
- K6F between Rabbit Lake TS and 115 kV Fort Frances TS,
- K3D between Rabbit Lake TS and 115 kV Dryden TS, and
- SK1 between Rabbit Lake TS and Seven Sisters GS in Manitoba, and
- All the loads in the Kenora area (Kenora Area Load); Kenora MS, Kenora DS, Abitibi Consolidated and Clearwater Bay DS.

## 6.2 Local Area Load Supply Considerations for Existing Loads

A set of system operating limits has been implemented in order to ensure the secure supply of the Kenora Area load. The sections below describe the basis for these operating limits.

### Kenora Area Inflow(KAI)

The KAI represents the sum of the MW flowing into Rabbit Lake via K3D and K6F plus the MW transfer through Kenora transformer T1 into the 115 kV system. This represents the power required to supply the Kenora Area Load in excess of the output of local generation.

The KAI limit is a function of the Kenora Area Load and the number of units in service at Whitedog Falls GS and Caribou Falls GS. To establish the relationship between KAI and the number of generating units required to be in service to ensure the reliable supply of the Kenora Area Load, the post contingency voltage decline criterion was used. This criterion requires that the post-contingency voltage decline at Rabbit Lake be less than 10% for the loss of any of the K7K 115 kV line or the Kenora transformer. The KAI limits are shown in Table 1.

**Table 1.** Kenora Area Inflow

KAI Limit Table – all Elements I/S					
Kenora Area Load (MW)	≤ 50	50 to 70	70 to 100	100 to 130	130 to 150
# Units Required I/S	0	1	3	4	6
Kenora Area Inflow Limit (MW)	50	70	100	130	130
KAI Limit Table – K7K or T1 O/S					
Kenora Area Load (MW)	≤ 50	50 to 70	70 to 100	100 to 130	130 to 150
# Units Required I/S	2	3	4	5	6
Kenora Area Inflow Limit (MW)	50	60	60	60	50

For example, with all area transmission elements in service if the KAL is 150 MW then the maximum allowable KAI is 130 MW, provided that there are 6 units in service at Whitedog Falls GS and Caribou Falls GS to supply the remaining load and ensure sufficient reactive support (it should be noted that all three Whitedog Falls GS units can be run in condense mode).

The operating limits for K7K or Kenora T1 out of service, are shown in the second part of the table. For a Kenora Area Load of 150 MW the maximum allowable KAI is 50 MW provided that there are 6 units in service at Whitedog Falls GS and Caribou Falls GS to supply the remaining load and also ensure sufficient reactive support. In this particular case the hydraulic generation output should be about 100 MW.

It should also be noted that a load rejection scheme was implemented in the Kenora Area, which ensures that for the loss of the single circuit K7K or the double circuit line K4W and K5W sufficient load is rejected to maintain stability in the area.

### **Kenora Area Outflow(KAO)**

Under conditions of surplus generation in the Kenora area, an operating limit was established to prevent Manitoba's Seven Sisters GS units, Whitedog Falls GS or Caribou Falls GS from going unstable for faults of K7K, T1, K3D or K6F. The limit is represented by the power flowing out of the Kenora Area (Kenora Area Outflow).

The KAO limit states that with all elements in service in the area the flow out of Kenora Area is limited to 100 MW when three units are in service at Seven Sisters GS. There are no restrictions for one or two units in service at Seven Sisters GS.

### **6.3.0 Incorporation of New Load in Local Area**

An analysis was performed to identify if the new proposed load has an impact on the local system reliability and the existing operating limits.

The effect of the additional load was studied for Kenora Area peak load conditions and maximum Kenora Area Inflow or Kenora Area Outflow situations. The study scenarios were selected to meet all the system operating limits. The load in the area was represented as active power varying with  $V^{1.5}$  and reactive power varying with  $V^2$ . The impact of the new load was assessed for scenarios where all local transmission elements (A) were in service and also (B) when one critical local transmission element, Kenora T1, was out of service.

#### **6.3.1 Kenora Area Inflow**

This section describes the study scenarios and results for cases where Kenora Area Load is higher than the local hydraulic generation output resulting in a power inflow into Kenora Area.

##### **Scenario (A)-All elements I/S**

The first study scenario included 150 MW of existing load in the Kenora area (no new load incorporated) and four units in service at Whitedog Falls GS and Caribou Falls GS. In this case, the generating units provide voltage support only. The Kenora Area Inflow was about 150 MW.

Similarly, the second study scenario included 150 MW of existing load in the Kenora area and the new Weyerhaeuser load of 16.5 MW. The scenario included four units in service at Whitedog Falls GS and Caribou Falls GS that provide voltage support only. The Kenora Area Inflow was about 168 MW.

##### **Scenario (B)-Kenora T1 O/S**

The first study scenario included 150 MW existing load in the Kenora area (no new load incorporated) and six units in service at Whitedog Falls GS and Caribou Falls GS. In this case, the load is supplied from the local generation and Kenora Area power Inflow of about 50 MW.

Similarly, the second study scenario included 134 MW of existing load in the Kenora area and the new Weyerhaeuser load of 16.5 MW, for a total load of 150 MW. In this case, the load is also supplied from the local generation and Kenora Area power Inflow of about 50 MW.

**Study Results**

The study results for scenarios (A) and (B) are shown in Table 2.

**Table 2.** Effect of Weyerhaeuser Load – Kenora Area Inflow

Case		Units I/S		Rabbit Lk. Voltage (kV)	Kenora 118 Voltage (kV)	Kenora 220 Voltage (kV)	Weyerhaeuser LT Voltage (kV)
		Whitedog GS	Caribou GS				
All element in service							
KAI=150 MW No new Load	Pre	3	1	121.5	123.9	239.2	N/A
	Loss of K7K	3	1	110.5	o/s	242.7	N/A
				-9.0%	o/s	1.5%	N/A
KAI=168 MW With new Load	Pre	3	1	120.9	123.3	236.5	13.79
	Loss of K7K	3	1	110	o/s	242.7	o/s
				-9.0%	o/s	2.6%	o/s
Kenora Transformer T1 or Kenora P bus o/s							
KAI=50 MW No new Load KAL=134 MW	Pre	3	3	120.4	N/A	245.3	N/A
	Loss Of K3D	3	3	116.1	N/A	245.2	N/A
				3.5%		0%	
	Loss of K6F	3	3	118.4	N/A	245.2	N/A
				1.7%		0%	
KAI=50 MW With New Load KAL=150 MW	Pre	3	3	119.2	118.5	245.8	13.75
	Loss Of K3D	3	3	115.5	114.9	245.9	13.32
				3.1%	3.1%	0%	3%
	Loss of K6F	3	3	117.4	116.8	245.8	13.54
				1.5%	1.4%	0%	1.5%

A comparison of the results obtained for the existing Kenora Area system configuration and a system configuration that includes the new load shows that the addition of the new Weyerhaeuser load does not increase the post contingency voltage decline at Rabbit Lake TS.

With all elements in service the pre-contingency voltage at Rabbit Lake 115 kV and Kenora 115 kV buses are slightly lower with the new load incorporated than without. It should be noted that

the Kenora 115 kV bus voltage meets the minimum voltage requirement of 122 kV when all transmission elements are in service.

With Kenora T1 out of service the pre-contingency voltage at Rabbit Lake 115 kV is slightly lower with the new load incorporated (119.2 kV) than without (120.4 kV). The results show that for outage conditions the Kenora 115 kV bus voltage meets the *Market Rules* minimum voltage requirement of 113 kV. Although in this case peak load was assumed, it is expected that transmission elements would not be scheduled for planned maintenance during times when the area load is at its peak.

The new Weyerhaeuser load does not have an adverse impact on the post-contingency voltage decline at Rabbit Lake TS, or Kenora TS, and does not influence the Kenora Area Inflow operating limit. Supply to the new load will continue to be provided when the Kenora transformer T1 is out service but will be interrupted when the 115 kV circuit K7K is out of service.

### 6.3.2 Kenora Area Outflow

A study was performed to identify whether or not the new proposed load influences the Kenora Area Outflow limit. As mentioned in section 6.2 the power flowing out of the Kenora area is limited to 100 MW only when three units are in service at Seven Sisters GS.

For comparison, two transient stability cases were set up with and without Weyerhaeuser load in service. The load flow models included all transmission elements in service and the following generation dispatch:

- three units in service at Seven Sisters GS,
- three units in service at Caribou Falls GS,
- two units in service at Whitedog Falls GS.

The Kenora Area Outflow was 110 MW for the case simulating the existing system configuration and 94 MW for the case with the Weyerhaeuser in service. Transient stability studies were performed for normally cleared three phase fault at Rabbit Lake TS on the 115 kV circuit K7K<sup>1</sup>. The results are plotted in Figure 3 for the study with the new load in service and Figure 4 for the existing system. For comparison purposes the figures are shown on the same page. A close look at the transient plots indicates that the transient stability behaviour is not impacted by the addition of the new load.

It should be noted that although the Kenora Area Outflow limit is lower in the case when Weyerhaeuser load is in service, the new load does not affect in any way the capability of the transmission system in the Kenora pocket or the capability of the local generation. The decrease in the maximum power that could exit the Kenora Area is a direct consequence of the increase in pocket load due to Weyerhaeuser new load.

---

<sup>1</sup> This is considered to be the worst contingency for the KOA scenario in spite of the fact that new load is lost by configuration. The loss of the new load results in an increase in the post-contingency Kenora Area Outflow.

Manitoba Hydro has indicated recently that the maximum number of units connected to SK1 will be limited to two. Although, it may be concluded that this operating limit is not applicable anymore, it was decided to carry out the study anyway.

The new Weyerhaeuser load does not have an adverse impact on the system transient stability because it does not reduce in any way the transfer capability of the system and does not limit the output of the local generation.

#### **6.4 Requirement for Load Rejection Scheme**

Existing system operating practices for the Kenora area, require that certain loads be tripped under contingency situations in order to avoid the collapse of the area due to excessive voltage decline. To meet this condition a load rejection scheme was installed at Abitibi Consolidated. The scheme trips any load that is over 75 MW for a contingency associated with K7K or the loss of the double circuit line K4W and K5W connecting to Caribou Falls GS and Whitedog Falls GS.

To maintain this operating criterion for the Kenora area it is required that a load rejection (L/R) scheme also be installed at the new plant. The L/R scheme must be able to trip the load for the loss of the double circuit line K4W and K5W. It is expected that Hydro One Network Inc. and Weyerhaeuser will work together to meet this requirement.

It is required that load rejection facilities be installed at Weyerhaeuser plant, which will ensure that the load is tripped for the loss of the 115 kV double circuit line K4W and K5W.

#### **7.0 Conclusions and Recommendations**

This Preliminary Assessment has examined the impact of connecting the new 6.5 MW Weyerhaeuser Mill load on the 115 kV circuit K7K. The assessment concluded the following:

1. Under the connectivity arrangement that was proposed by the applicant, the new load cannot be supplied when the 115 kV circuit K7K is out of service.
2. The connection applicant has indicated that the new developments will be operated at 0.95 power factor and this is acceptable under the *Market Rules*.
3. The addition of the new supply point does not have an effect on the short circuit current in the area.
4. Because this load is under 20 MVA there is no requirement under the *Market Rules* for installation of monitoring facilities or voltage reduction facilities.
5. The new Weyerhaeuser load does not have an adverse impact on the post-contingency voltage decline at Rabbit Lake TS, or Kenora TS, and does not influence the Kenora Area Inflow operating limit.

6. The new Weyerhaeuser load does not have an adverse impact on the system transient stability because it does not reduce in any way the transfer capability of the system and does not limit the output of the local generation.
7. It is required that load rejection facilities be installed at Weyerhaeuser plant, which will ensure that the load is tripped for the loss of the 115 kV double circuit line K4W and K5W.

It is required that Weyerhaeuser provide the IMO with the following information as soon as it becomes available:

8. A confirmation that a underfrequency load shedding relay, which will have the capability of tripping up to 35% of the station load (12% at 59.3 Hz and additional 23% at 58.8 Hz) is to be installed. It is required that the connection applicant provide information on load distribution and the most likely operation of the plant prior to commissioning to enable the IMO to supply appropriate settings for the relay.

### **8.0 Identification of “Sole Beneficiary”**

Section 9.2.5 of the Transmission System Code states that “modifications and upgrades on specific network facilities or installation of new network facilities that are triggered by a load customer and are for its sole benefit of shall be borne by the customer.”

The IMO considers that the installation of load rejection facilities is for the sole benefit of the Weyerhaeuser proposed development in the Kenora area.

### **9.0 Hydro One Customer Impact Assessment**

Hydro One has performed a Customer Impact Assessment for the new proposed connection. The CIA review included the following potential impacts on existing customers:

- Short circuit impact at the connection point
- Voltage performance at the connection point
- Impact on supply reliability of the connection line

The Customer Connection Assessment concluded that the new proposed Weyerhaeuser connection does not impact the existing customers connected to the IMO-controlled grid.

### **10.0 Notification of Approval**

Section 7.0 of the Preliminary Assessment Report lists all the requirements identified by the IMO for the incorporation of the proposed Weyerhaeuser plant in Kenora Area. It is recommended that approval be granted and Notification of Approval be issued subject to the acceptance by the proponent of the IMO requirements.

Kenora Area Inflow = A+B+C  
 Kenora Area Outflow = -(A+B+C)

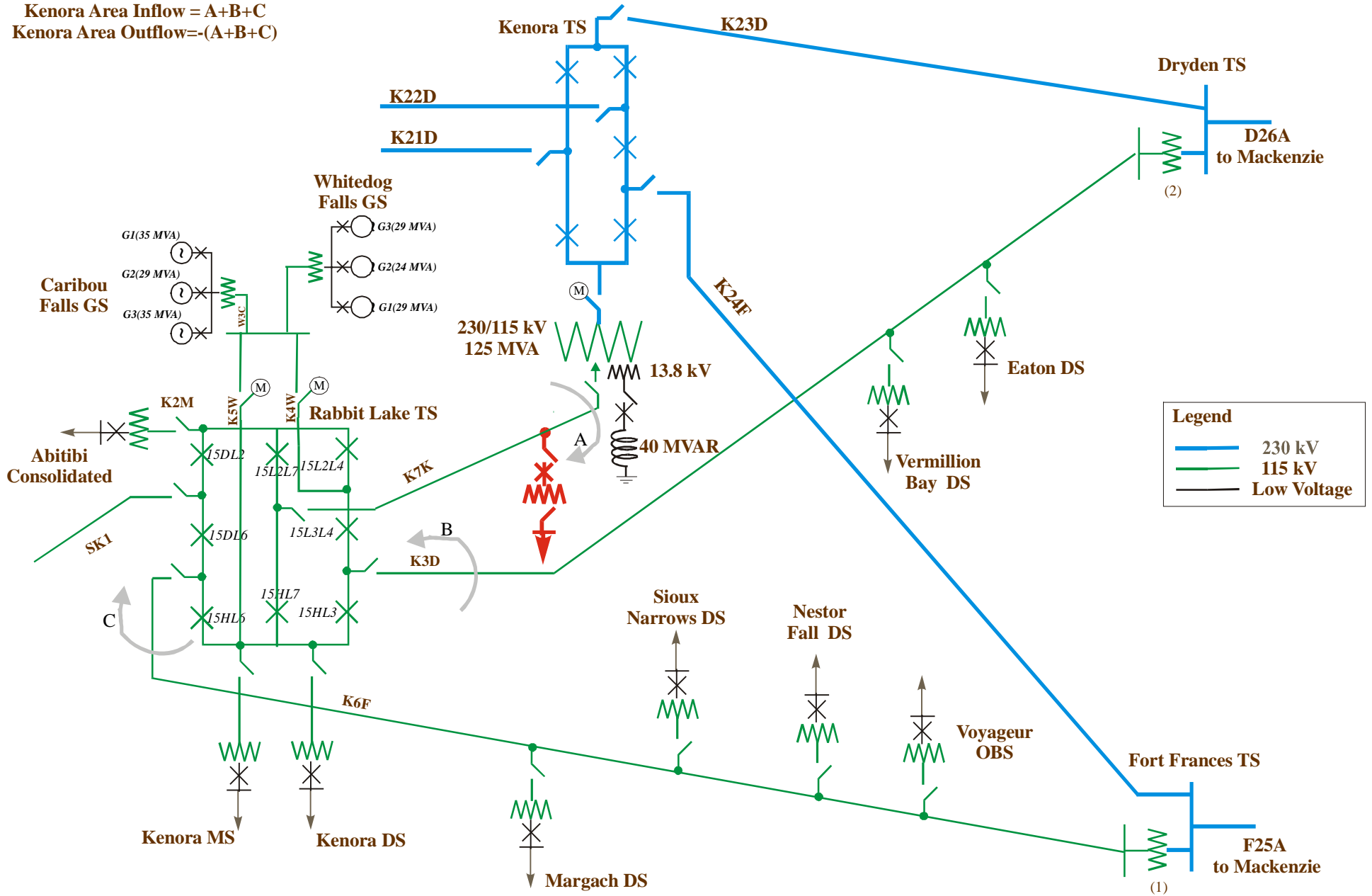

Figure 1. Kenora Area Transmission Configuration - Weyerhaeuser Proposed Connection

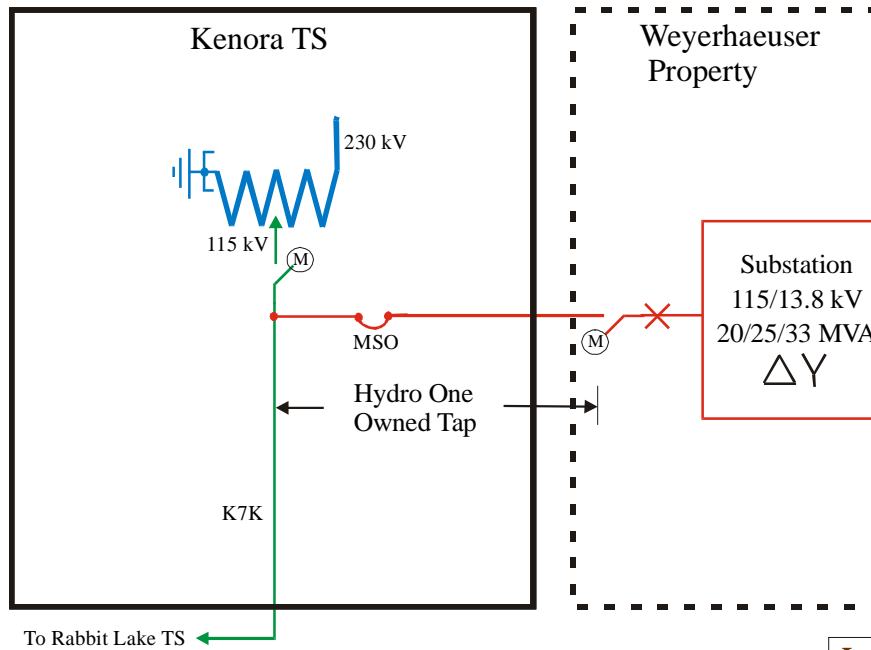

Figure 2A. New Weyerhaeuser Connection - Preferred Alternative

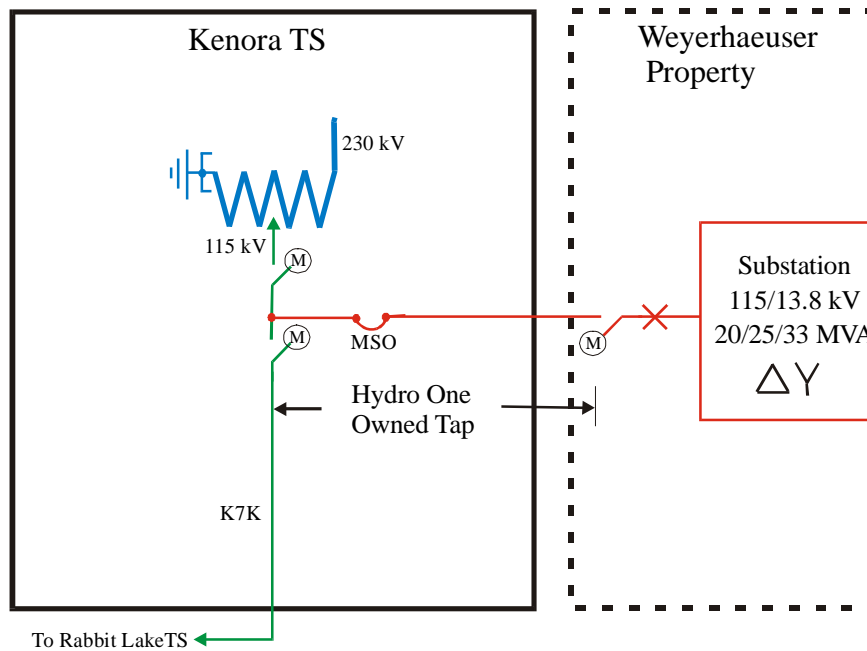

Figure 2B. New Weyerhaeuser Connection - Optional Alternative

334-1.SAV BASED ON 334-S000AA.SAV, FIXING 7S&CAMERON F GS  
 ND=1950,MH=1946,MN=2652,MHOH=-204,OHMP=150,EWTW=-200,BD=165  
 3-PHASE FAULT ON K7K AT RABT LK, SPLIT BUS 9999, LOSS OF WEY

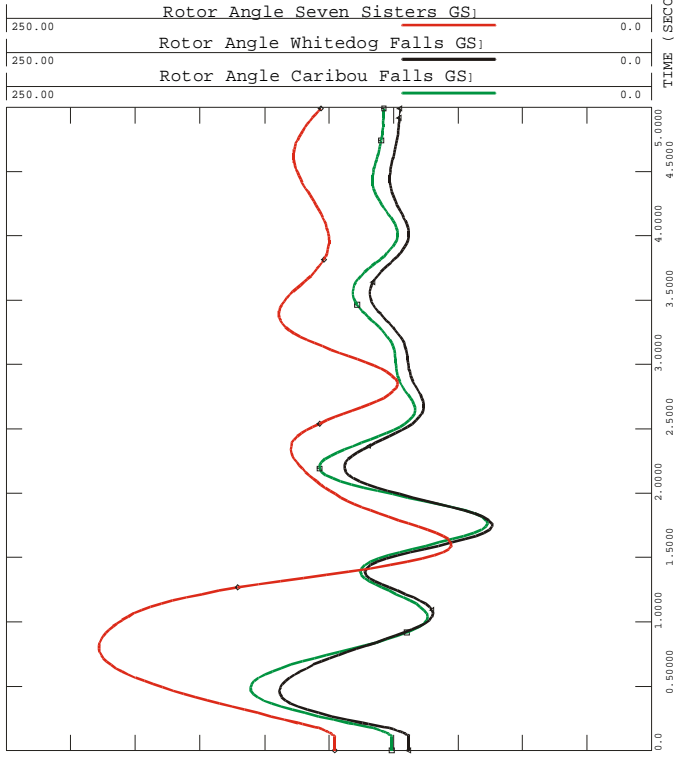

Figure 4A. Rotor Angle Plots-Witout New Load

334-1.SAV BASED ON 334-S000AA.SAV, FIXING 7S&CAMERON F GS  
 ND=1950,MH=1946,MN=2652,MHOH=-204,OHMP=150,EWTW=-200,BD=165  
 3-PHASE FAULT ON K7K AT RABT LK, SPLIT BUS 9999, LOSS OF WEY

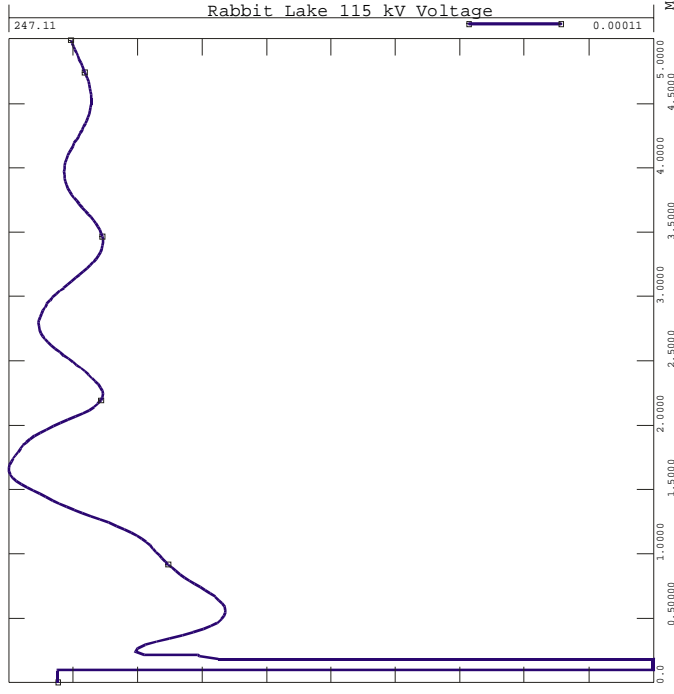

Figure 4B. Voltage Plot-Witout New Load

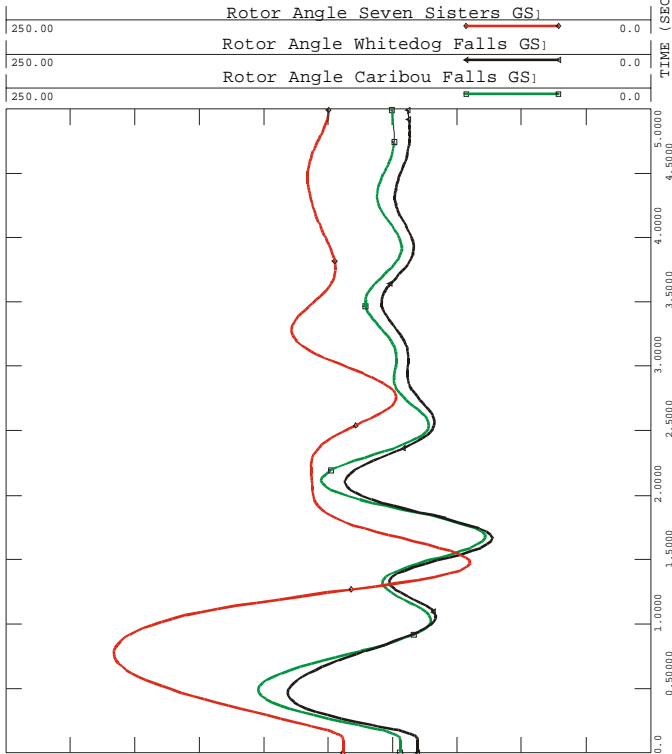

Figure 3A. Rotor Angle Plots-With New Load

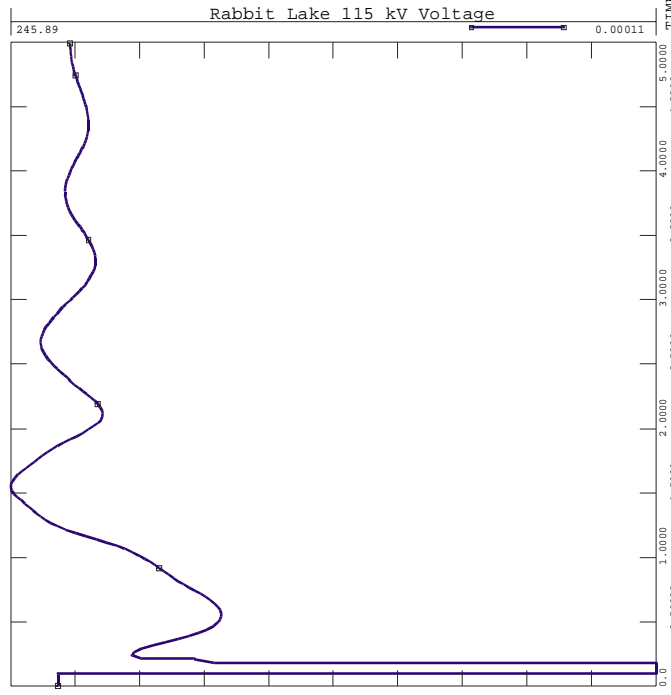

Figure 3B. Voltage Plot-With New Load