



# CONNECTION ASSESSMENT & APPROVAL PROCESS

## Preliminary Assessment Report

**Project:** *High Falls GS Redevelopment*

**Applicant:** *Great Lakes Power Ltd. – Generation Division*

**CAA ID 2002-069**

## Final Report

Long Term Forecasts & Assessments Department  
Consistent Information Set Department

February 14, 2003



## **Preliminary Assessment Report**

High Falls GS Redevelopment

### **Acknowledgement**

The IMO wished to acknowledge the assistance of Great Lakes Power Limited-Transmission Division in completing this assessment.

### **Disclaimers**

#### **IMO**

This report has been prepared solely for the purpose of assessing, on a preliminary basis, whether the connection applicant's proposed connection with the IMO-controlled grid would have an adverse impact on the reliability of the integrated power system and whether a System Impact Assessment of the proposed connection should be conducted under Chapter 4, section 6 of the *Market Rules*. This report has not been prepared for any other purpose and should not be used or relied upon by any person for another purpose. This report has been prepared solely for use by the connection applicant, Great Lakes Power Limited and the IMO in accordance with Chapter 4, section 6 of the *Market Rules*. The IMO assumes no responsibility to any third party for any use which it makes of this report. Any liability which the IMO may have to the connection applicant in respect of this report is governed by Chapter 1, section 13 of the *Market Rules*. In the event that the IMO provides a draft of this report to the connection applicant, you must be aware that the IMO may revise drafts of this report at any time in its sole discretion without notice to you. Although the IMO will use its best efforts to advise you of any such changes, it is the responsibility of the connection applicant to ensure that it is using the most recent version of this report.

The additional facilities or upgrades which are required to incorporate the proposed connection have been identified to the extent permitted by a preliminary assessment under the current IMO Connection Assessment and Approval process. Additional facility studies may be necessary to confirm constructability and the time required for construction. Further studies at more advanced stages of the project development may identify additional facilities that need to be provided or that require upgrading.

## **Preliminary Assessment Report**

For the proposed 50 MVA Redevelopment of High Falls GS by  
Great Lakes Power – Generation Division

### **1.0 Project Description**

Great Lake Power Limited – Generation Division has almost completed the construction on two new generating units at High Falls GS on the Michipicoten river located about 25 km south-east of Wawa. The new plant will replace the existing three aging units which have a total generating capability 27.7 MVA. Each new unit will have a rated capability of 25 MVA with a Maximum Continuous Rating of 28.75 MVA. Based on the information provided by Brascan Power, at the completion of construction and commissioning, the new plant will be open for service and the existing plant will be taken off line. With the new plant the net power injection at D.A. Watson into the IMO- controlled grid will increase by up to 29.8 MVA over the existing plant.

The in service date for the new generators is January 2003.

### **2. Connection Arrangement**

Each new hydraulic units will be connected via an LV breaker, a 12.0/34.5 kV step-up transformer to a 34.5 kV feeder which connects into the 34.5/115 kV D.A. Watson TS. The two feeders are equipped with 34.5 kV in-line breakers and connect to 34.5 kV Bus1 and Bus2 at D.A. Watson TS, respectively.

Hence the new generation is embedded into the distribution system and the connection to the IMO-controlled grid is not to be altered.

### **3. Data Verification**

The connection applicant has provided complete dynamic models for the new generators, the excitation systems and the governors.

#### **3.1 Generator Model**

Data for the generator model for each unit are as follows:

$$T'D0 = 4.17, T''D0 = 0.034, T''Q0 = 0.13, H = 3.86,$$

$$XD = 0.88, XQ = 0.57, X'D = 0.19, X''D = 0.14, XL = 0.07, X2 = 0.16, X0 = 0.05$$

$$S(1.0) = 0.22, S(1.2) = 0.49$$

The Market Rules state that each synchronous facilities connected to the IMO-Controlled Grid shall have the capability to supply reactive power within the range between 90% lagging (overexcited) and 95% leading (underexcited) power factor based on rated active power at rated voltage. The generator Reactive Capability Curves provided by the applicant indicate that, at rated active power output (22.5 MW) each unit is capable of absorbing or producing about 11.25 Mvar.

This capability exceeds the Market Rules requirements with respect to the reactive power absorbing capability.

### 3.2 Excitation System

The excitation system information that was provided by the connection applicant, including the block diagram and data, is shown in Figure 1. It is composed of a type ST1 potential source-controlled rectifier exciter and no stabilizer.

*The excitation system model and data is to be finalized by the connection applicants upon the completion of commissioning test and provided the IMO in view of completing the Facility Registration Process.*

Appendix 4.2 of the Market Rules lists a number of performance requirements for embedded and non-embedded generators that are imposed in order to ensure the maintenance of the IMO-controlled grid reliability.

#### *Reference #13*

Each synchronous generating unit rated 10 MVA or higher shall be provided with a continuously acting automatic voltage regulator (AVR) which shall be able to maintain over its entire operating range a steady state terminal voltage of +0.5% of the set point.

#### *Reference #12*

Each synchronous generating unit that is rated at 10 MVA or larger shall be equipped with an excitation system with voltage response time not longer than 50 ms, and ceiling voltage at least twice the rated filed voltage.

#### *Reference #15*

Each synchronous generator unit rated at 10 MVA or larger shall be equipped with a power system stabilizer when requested by the IMO. The purpose of a power system stabilizer is to produce an electrical torque in phase with speed changes thus providing sufficient damping to system transient oscillations.

#### *Exciter Performance Study Results*

Dynamic simulations were performed to verify that the transient response of the new units excitation systems meets this particular rule. The results of the exciter system voltage response test to a 5% step change in terminal voltage are displayed in Figure 2. Examination of the plots indicate that:

- the exciter field voltage reaches 95% of the excitation ceiling voltage in less than 50 ms, thus meeting the above-mentioned requirements,
- the exciter ceiling voltage exceeds the Market Rules requirements<sup>1</sup> and
- the proposed exciter provides adequate damping of system oscillations.

---

<sup>1</sup> From the generator's V curves the rated field voltage is 1.91 pu. Hence, the filed voltage must reach  $2 \times 1.91 = 3.82$  pu. The graph shows that the ceiling exciter voltage is 5 pu.

Although, the damping provided by this exciter is adequate the exciter gain must be set to about 200 in order to meet the requirement described under reference #13. This will result in a more oscillatory transient response for the new units, thus necessitating the installation of a stabilizer

*Requirements – High Falls Excitation Systems*

The IMO requires that a power system stabilizer must be provided with each unit excitation system, but acknowledges that meeting this requirement at the time of commissioning may jeopardize the planned in service date of the development.

Hence the IMO's allows the applicant to proceed with the connection of the two generating units, subject to meeting the following requirements with respect to the excitation system:

1. As soon as the commissioning tests are completed and actual data is available, the connection applicant is required to provide an updated block diagram model of the excitation system. Using these data the IMO will performed studies to verify the behaviour of the excitation system and establish the need for any new controls and adjustments, as part of the Facility Registration Process.

However, if the new model exhibits similar performance to the model that has been studied in this assessment then:

2. The connection applicant must request from the IMO a temporary exemption to the market rule that requires the automatic voltage control to maintain the terminal voltage within 0.5% of nominal value,

3. The connection applicant must install a power system stabilizer on each High Falls unit not later than August 1, 2003,

4. Coincident with the installation and tuning of the power system stabilizer the exciter gain must be set to 200 and the exemption granted under point 2. above will expire.

### **3.3 Governor Model**

The hydraulic governor block diagram and data that was submitted by the applicant, after the completion of commissioning tests, for High Falls generating units are shown in Figure 3.

Appendix 4.2 of the Market Rules requires that every synchronous generator unit with a name plate rating greater than 10 MVA or larger be operated with a speed governor, which shall have a permanent speed droop that can be set between 3% and 7% and the intentional dead band shall not be wider than + 36 mHz. The hydraulic governor droop for the High Falls units is set to 5%.

Dynamic simulations were performed to verify the transient response of the governor in isolation of the rest of the system, to a load step change of 10%. The results are displayed in Figure 4. Examination of the plots indicates that the governor response is well damped.

#### **4. Short Circuit Assessment**

Great Lakes Power Limited Transmission Division has performed a short-circuit analysis and assessed the effect of the new generation development on the existing short-circuit levels at Watson TS and Anjigami TS. The results indicate that the incorporation of the new High Falls GS will result in an increase in the three-phase and line-ground short circuit levels at Anjigami TS between 5% and 6.4%.

Detailed short circuit studies also revealed that with all facilities in service the interrupting capability of the Anjigami TS 115 kV breakers is being presently exceeded for a line to ground fault. Great Lakes Power Limited has already initiated a program to replace the 115 kV breakers at this station as part of a greater redevelopment project. Presently, the transmitter and the IMO are working on interim operational measures to ensure the fault level is kept below the Anjigami TS breaker capability until the installation of the new equipment is complete.

It can be concluded that although the proposed development raises the short circuit currents by up to 6.4%, the need to replace the breakers at Anjigami TS should not be attributed to this project because the breakers are presently underrated.

#### **5. Local Thermal Loading Considerations**

A diagram showing the GLP transmission system and the proposed connection of the new generation is presented in Figure 5. The bubble in the upper left corner details the local system that is likely to be affected by the additional generation. It was calculated that the new development is going to result in a net increase of 29.8 MVA over the existing plant.

A power flow analysis was carried out for the following summer system conditions:

- All transmission elements in service
- Available generation of 135.5 MW equivalent to maximum continuous rating of all area units,
- Load at D.A. Watson equivalent to the off-peak summer load of 2.7 MW.

GLP Transmission has provided all the required information on the rating of their transmission facilities. Table 1 below summarizes the ratings of this 115 kV system and the results of the power flow analysis.

Table 1. Rating of Transmission Elements

Transmission Element	Continuos @120 kV		15 minute LTR @120 kV		Pre-contingency Max. Flow (MW) % of summer rating	Post-contingency Max. Flow		
	Summer (MVA) ONAF	Winter (MVA)	Summer MVA	Winter		Loss of DA Watson T1 % of LTR	Loss of DA Watson T2 or No.2 High Falls Line % LTR	Loss of No.1 High Falls Line % of LTR
DA Watson T1	75	N/A	116	N/A	42.4 56%	-	84.8 73%	-
DA Watson T2	75	N/A	116	N/A	42.4 56%	84.8 73%	-	84.8 73%
No.1 High Falls 115kV Line	97	133	100	146	90.4 93%	42.4 38%	132.8 133%	-
No.2 High Falls 115kV Line	102	135	113	154	42.4 41.6%	84.8 63%	-	84.8 63%

The results of this assessment, that was performed based on the equipment thermal ratings available from the connection applicant, indicate that for a system with all elements in service:

1. The pre-contingency power flows are well with the continuous rating of the transmission facilities,
2. A contingency associated with D.A. Watson transformer T1 will result in the post-contingency loading of T2 over its continuous rating, but under its 15 minute LTR,
3. A contingency associated with D.A. Watson transformer T2 or No.2 High Falls 115 kV circuit will result in the loading of T1 under its 15 minute LTR and the No.1 High Falls 115 kV circuit over its 15 minute “summer LTR” but will not exceed the circuit’s winter LTR, and
4. A contingency associated with No.1 High Falls 115 kV circuit will result in the loading of T1 over its continuous rating, but under its 15 minute LTR.

For the contingencies described under points 2 and 3, operating procedure will be implemented to ensure that if any of these contingencies occur the generation will be reduced within 15 minutes to bring the power flows on the remaining transmission below its continuous rating.

It can be concluded from these results that the 115 kV No.1 High Falls will become limiting during summer for a contingency associated with No.2 High Falls 115 kV circuit. To address this thermal overloading it is required to either:

- Install a contingency based automatic generation rejection scheme that will trip selected Michipicoten river hydraulic units. The scheme will be required to trip an amount of generation equivalent to the difference between the calculated post-contingency flow on the limiting circuit and its continuous rating,

Or

- Upgrade the 115 kV No.1 High Falls circuit to a higher rating.

The IMO requires that GLP-Generation Division initiate work for either:

- the installation of a contingency based automatic generation rejection scheme which will trip an amount of generation equivalent to the difference between the calculated post-contingency flow on the 115 kV No.1 High Falls circuit and its continuous rating.

Or

- Upgrading the 115 kV No.1 High Falls circuit to a higher rating

## 6. Impact on Interface Flows

The maximum net increase in generation that will result from the replacement of the existing High Falls GS with the new units is about 29.8 MW and it will be injected into the IMO-controlled grid at Anjigami 115 kV SS.

This additional power will distribute over the transmission system as follows:

- 37.5% (up to 11.2 MW) will flow over each Wawa 115/230 kV transformer into the 230 kV system
- 12% (up to 3.6 MW) will flow on No.1 Anjigami 115 kV circuit to MacKay TS and
- 13% (up to 3.9 MW) will flow on No.2 Anjigami 115 kV circuit to MacKay TS

The relative increase in power flowing over the neighbouring transmission system is shown in Figure 6.

The results of this analysis indicate that:

- the flow on each Wawa TS 115/230 kV transformer, with a continuous rating of 125 MVA, would increase by about 11.2 MW but is not likely to result on the overloading of these transformers, and
- the additional generation will result in a slight reduction in the East-West transfer east but will contribute to flow west on the East-West interface.

The overall conclusion is that the redevelopment of the High Falls generating complex will not have a significant effect on the reliability of the IMO-controlled grid, although under certain system condition it may contribute to congestion on the East- West tie.

## 7. Transient Stability Assessment

The transient stability analysis was performed for a line-to-line-to-ground fault on the high side of the D.A Watson transformer T2 and the permanent disconnection of T2 and #2 High Falls 115 kV circuit. Plots of machine rotor angles, transient voltages and power flows for five seconds, are shown in Figure 7.

The results show that the High Falls generating units display stable performance and the system oscillation are well damped.

The results also indicate that the McPhail GS units display sustained rotor angle oscillations and do not meet the generators transient stability performance requirements. These results could be due to an error in the excitation system model that was submitted to the IMO or could be an indication that the McPhail GS exciter settings are not matched with the machine characteristics.

Great Lakes Power-Generation Division is required to submit to the IMO a plan for bringing the McPhail GS units in *compliance* with the transient stability performance requirements. This can be achieved by firstly performing exciter system tests to validate exciter model. If the tests indicate that the oscillatory problem is real then, adjustments will be required to provide sufficient damping torque.

## 8. Generation Operation Requirements for Underfrequency System Conditions

The Market Rules require that generating facilities be able to operate continuously at full power for a system frequency range between 59.4 to 60.6 Hz. For underfrequency system conditions the generators shall not trip for frequency variations that are above the curve shown in Figure 8. However, if this cannot be achieved then automatic load shedding equivalent to the amount of generation to be tripped must be provided in the area. This criterion is required to ensure the maintenance of the stability of an island, if formed, and to avoid major underfrequency load shedding in the area.

## 9. Conclusions

This Preliminary Assessment examined the effect on the reliability of the *IMO-controlled grid* of the High Falls generation redevelopment carried out by Great Lakes Power-Generation Division.

The studies concluded that:

1. The new development is going to result in a net generation increase of 29.8 MVA over the maximum output of the existing plant, thus augmenting the Ontario generation resources.
2. The excitation systems models do not meet the Market Rules for automatic voltage control. As soon as the commissioning tests are completed and actual data is available, the connection applicant is required to provide an updated block diagram model of the excitation systems. Using these data the IMO will performed studies to verify the behaviour of the excitation system and establish the performance requirements, as part of the Facility Registration Process.
3. The new generating units contribute about 6.4% to the fault levels at D.A. Watson and Anjigami TS. Because the existing Anjigami breakers are presently under-rated, the transmitter and the IMO are working on interim operational measures to ensure the fault level is kept below the Anjigami TS breaker capability.
4. The pre-contingency power flows on the 115 kV transmission between D.A. Watson and Anjigami TS are well with the continuous rating of the respective transmission facilities.
5. A contingency associated with D.A. Watson transformer T1 will result in the post-contingency loading of T2 over its continuous rating, but under its 15 minute LTR,
6. A contingency associated with D.A. Watson transformer T2 or No.2 High Falls 115 kV circuit will result in the loading of T1 under its 15 minute LTR and the No.1 High Falls 115 kV circuit over its 15 minute “summer LTR” but will not exceed the circuit’s winter LTR, and
7. A contingency associated with No.1 High Falls 115 kV circuit will result in the loading of T1 over its continuous rating, but under its 15 minute LTR.
8. Due to the additional generation at High Falls TS, the flow on each Wawa TS 115/230 kV transformer would increase by about 11.2 MW but it is not likely to result on the overloading

- of these transformers, and
9. The additional generation will result in a slight reduction in the East-West transfer east and will contribute to flow west on the East-West interface.
  10. The transient stability performance of the system is not adversely affected by the new High Falls generating units.

The studies concluded that subject to implementation of the requirements identified in section 10,

- the proposed facilities have no adverse impact on the reliability of the existing *IMO-controlled grid* equipment;
- the incorporation of the proposed facilities does not reduce the load meeting capability of the *IMO-controlled grid*;
- the incorporation of the proposed facilities does not degrade the existing system transfer capability;

#### **10. IMO Connection Requirements**

This section summarizes the requirements identified during this PA for incorporating the new High Falls GS into the GLP distribution system. Great Lakes Power – Generation Division is required to:

1. Submit to the IMO an accurate model of the excitation systems upon completion of the High Falls commissioning tests. Using these data the IMO will performed studies to verify the behaviour of the excitation systems and, if necessary establish the need for any new controls and adjustments to the installed control systems. Until the IMO completes these studies and is satisfied that the development meets the Market Rules requirements, the total output of the new High Falls GS will be limited to the maximum output of the old High Falls GS which had an installed capacity of 26 MW.
2. The IMO requires that GLP-Generation Division initiate work for either:
  - the installation of a contingency based automatic generation rejection scheme which will trip an amount of generation equivalent to the difference between the calculated post-contingency flow on the 115 kV No.1 High Falls circuit and its continuous rating.Or
  - the upgrading of the 115 kV No.1 High Falls circuit to a higher rating

#### **11. IMO Compliance Requirements**

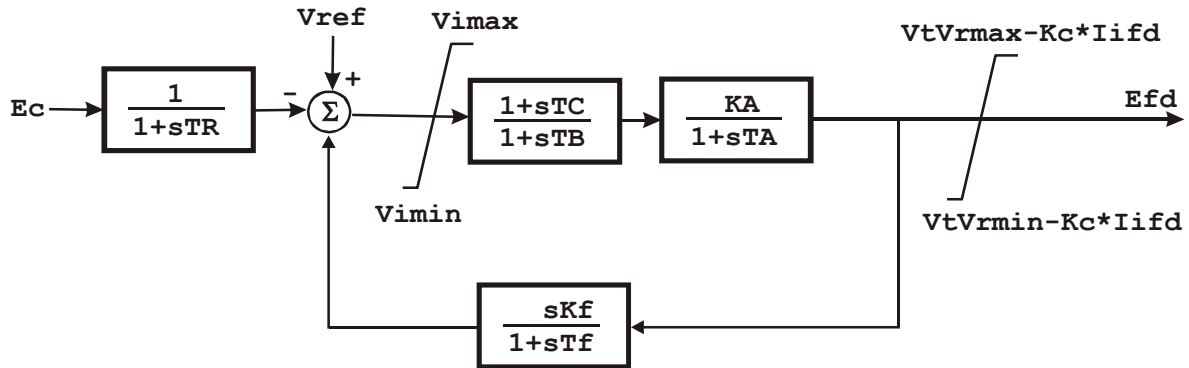
Transient stability studies, displayed in Figure 7, showed that the existing Mcphail GS units display sustained rotor angle oscillations and do not meet the generators transient stability performance requirements. Exciter time response tests were performed and the plots displaying very oscillatory response were included in Figure 9.

Great Lakes Power-Generation Division is required to present to the IMO a plan for bringing the McPhail GS units in *compliance* with the transient stability performance requirements. This can be achieved by firstly performing exciter system tests to validate exciter model. If the tests indicate that the oscillatory problem is real then, adjustments of the control system will be required.

## **12. Notification of Approval**

This Preliminary Assessment has assessed the impact of the new High Falls GS project on the *IMO-controlled grid* and has identified IMO's requirements for connection to ensure no negative effect on the reliability of the *IMO-controlled grid*.

It is recommended that a *Notification of Approval* be granted for this project, subject to the implementation of the requirements stipulated in section 10 of this report.

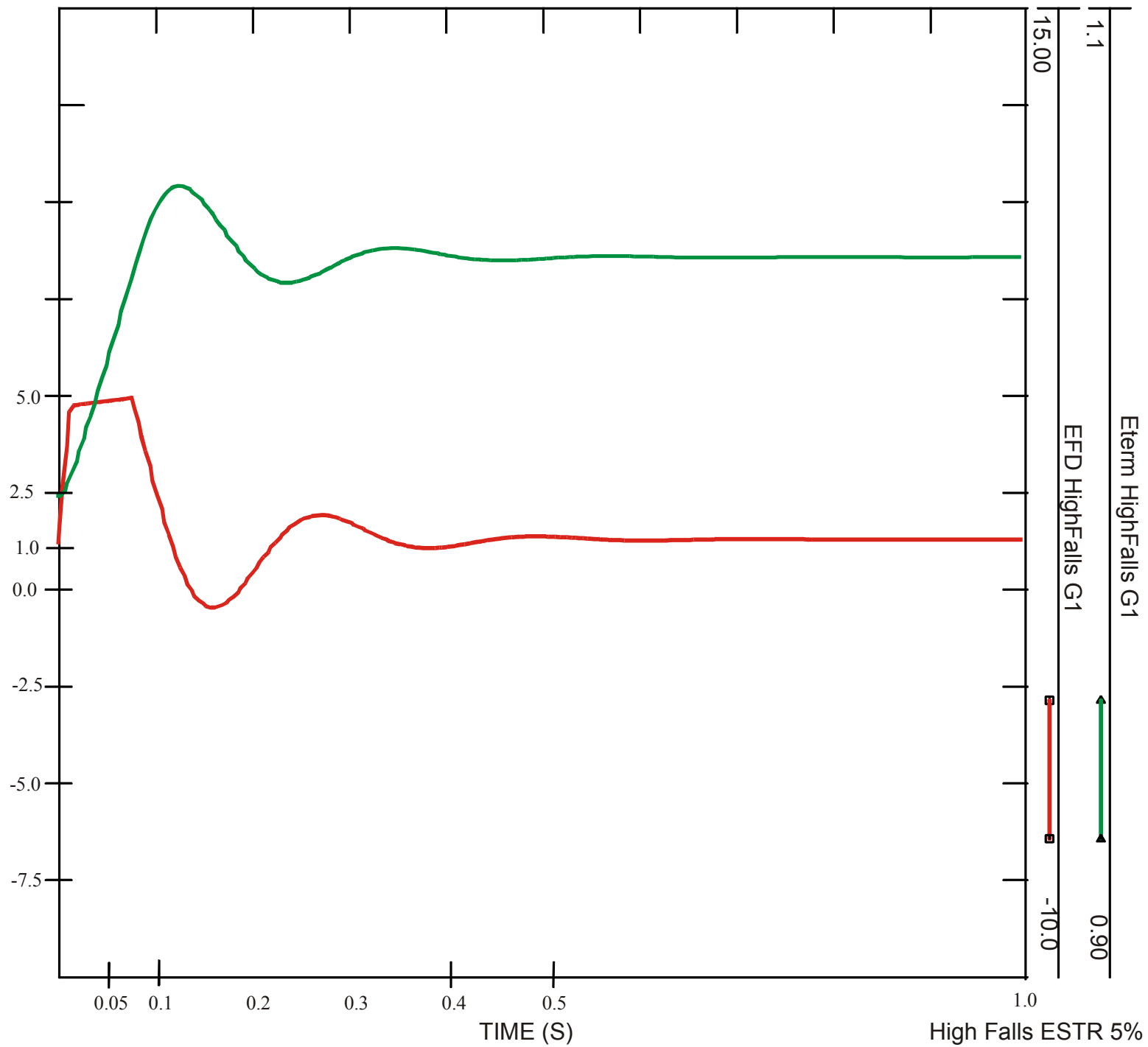


$TC=1.0$     $TB=1$     $TA=0.02$     $TR=0.01$     $Tf = 1.0$     $KA=150$     $VImax=9999$     $VImin=-9999$   
 $VRmax=4.8$     $VRmin=-4.4$     $KC=0$     $Kf=0$

IEEE Type St1 Exciter Model

FIGURE 1. Exciter Models for High Falls G1 & G2





**Figure 2. Exciter Time Response Test**

# Woodward P.I.D. Hydro Governor

## High Falls Redevelopment G1 and G2

0.25	$T_{REG}$ (Seconds)
5%	Reg
3.0	$K_P$
0.7	$K_I$
<b>0.1</b>	<b><math>K_D</math></b>
0.016	$T_A (>0)$ (Seconds)
0.16	$T_B (>0)$ (Seconds)
12%	VELMX
-6.5%	VELMN (<0)
100%	GATMX
0%	GATMN
1.21	$T_W (>0)$ (Seconds)
22.5	$P_{MAX}$ (MW)
0.0	$P_{MIN}$ (MW)
5%	D
N/A	$G_0$
N/A	$G_1$
N/A	$P_1$
N/A	$G_2$
N/A	$P_2$
N/A	$P_3$

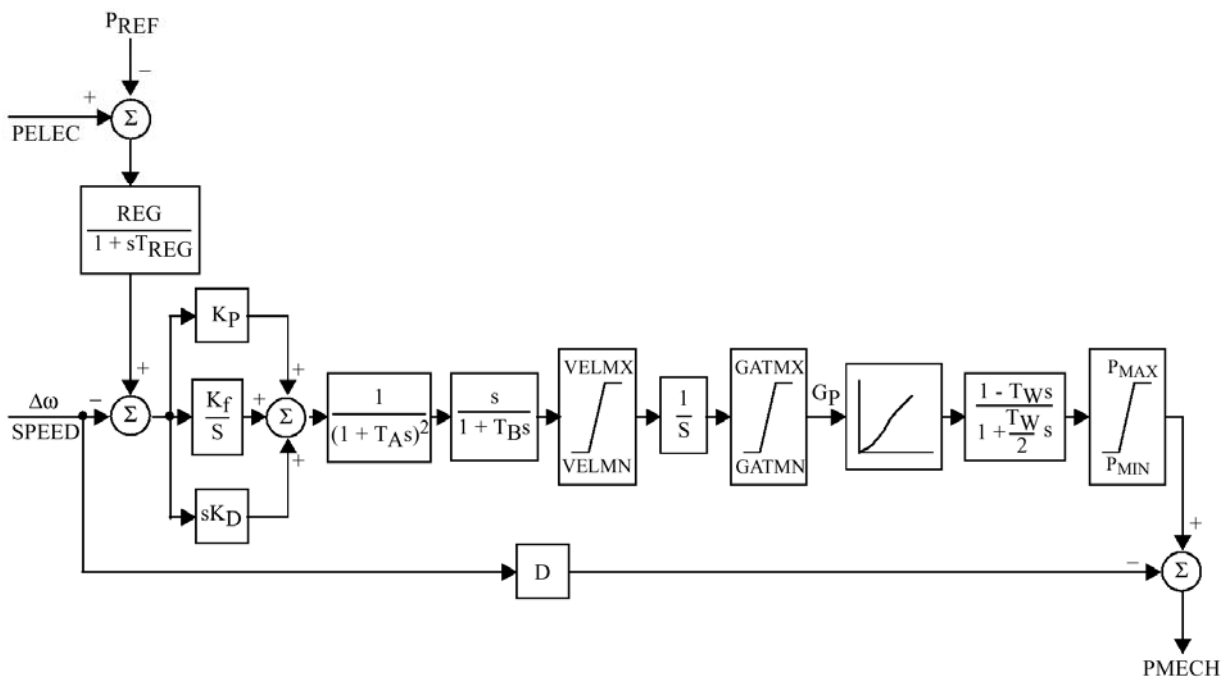
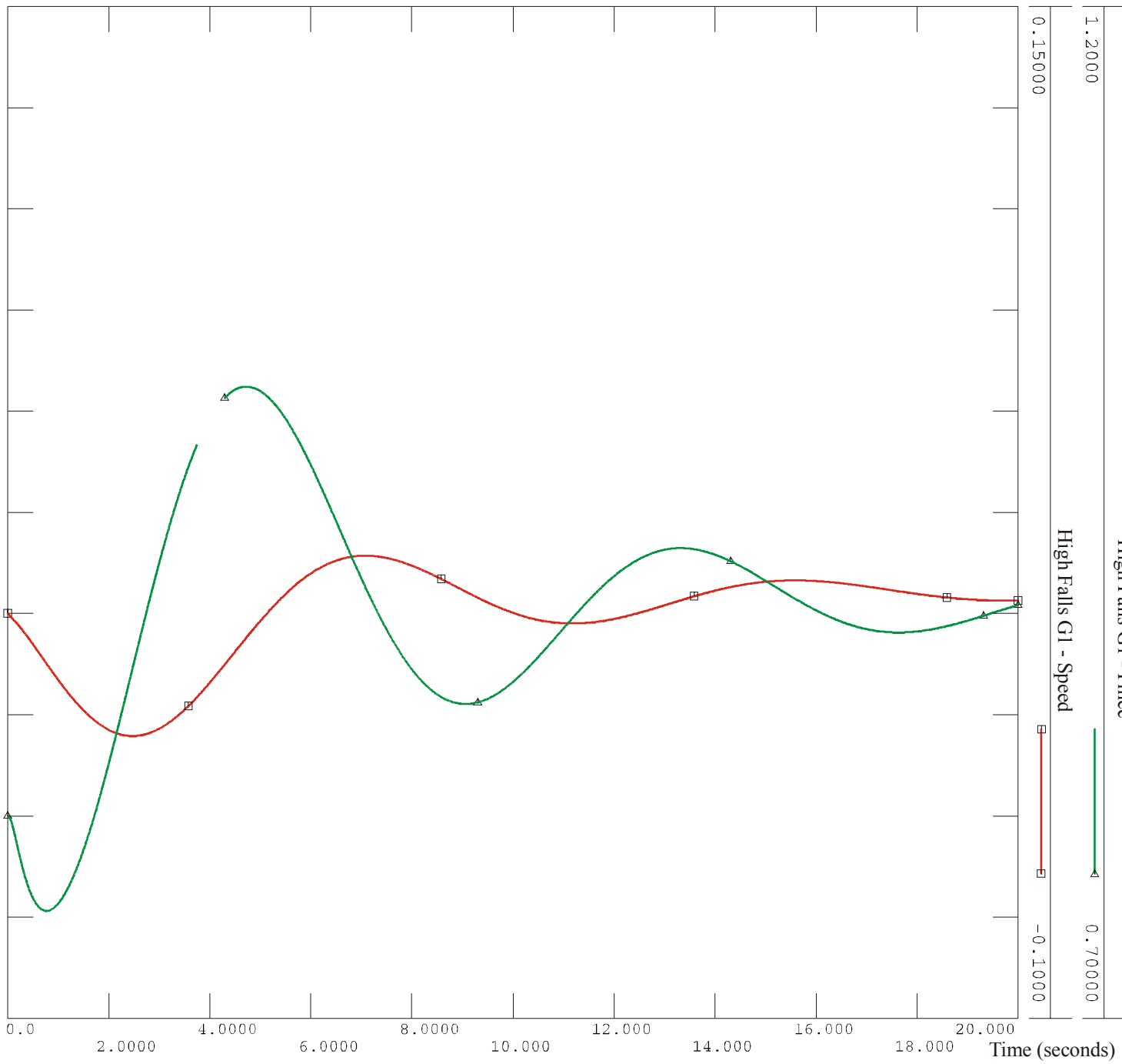


Figure 3. High Falls GS – Governor model



**Figure 4. High Falls Governor Response to 10% Load Change (at 80%output)**

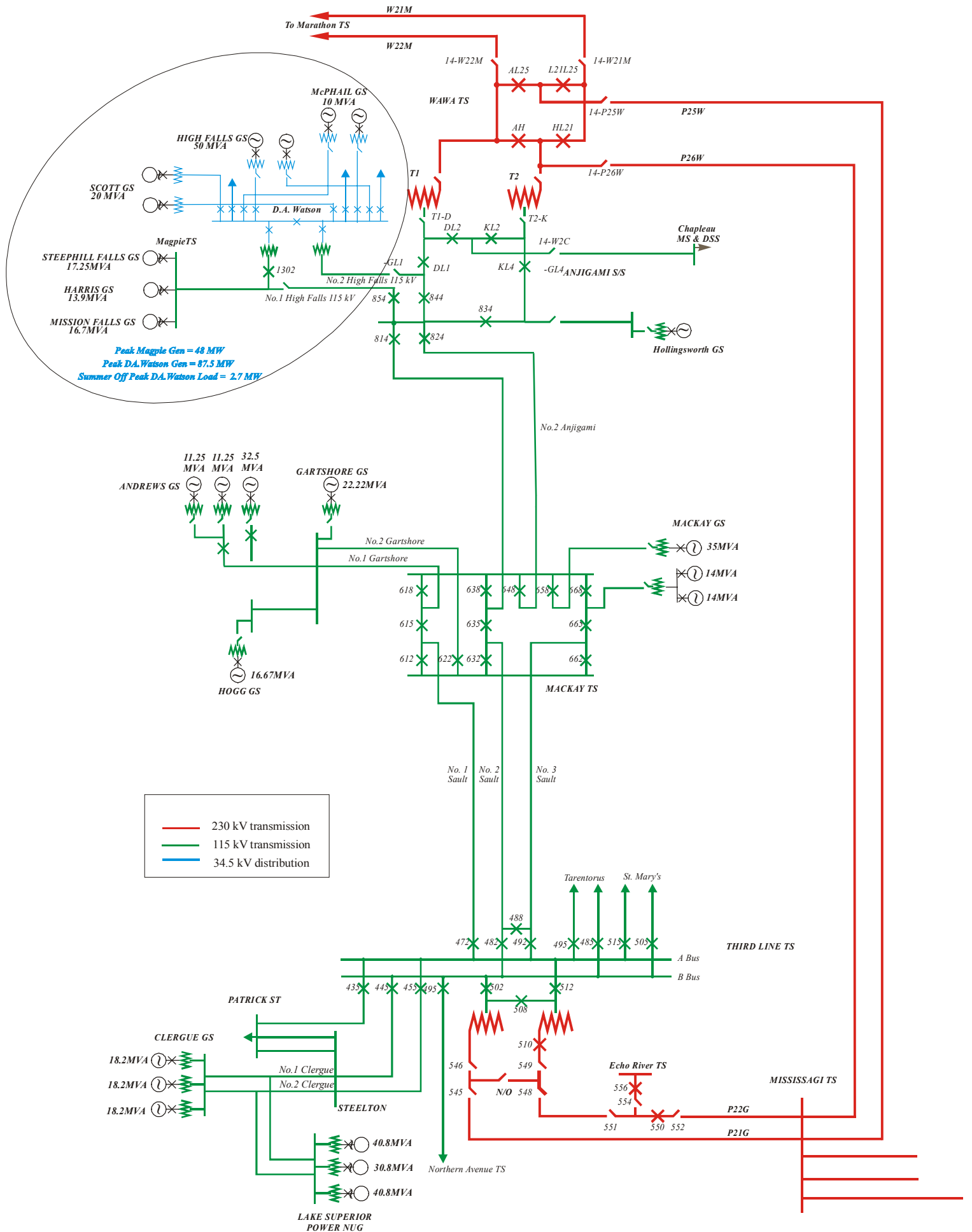
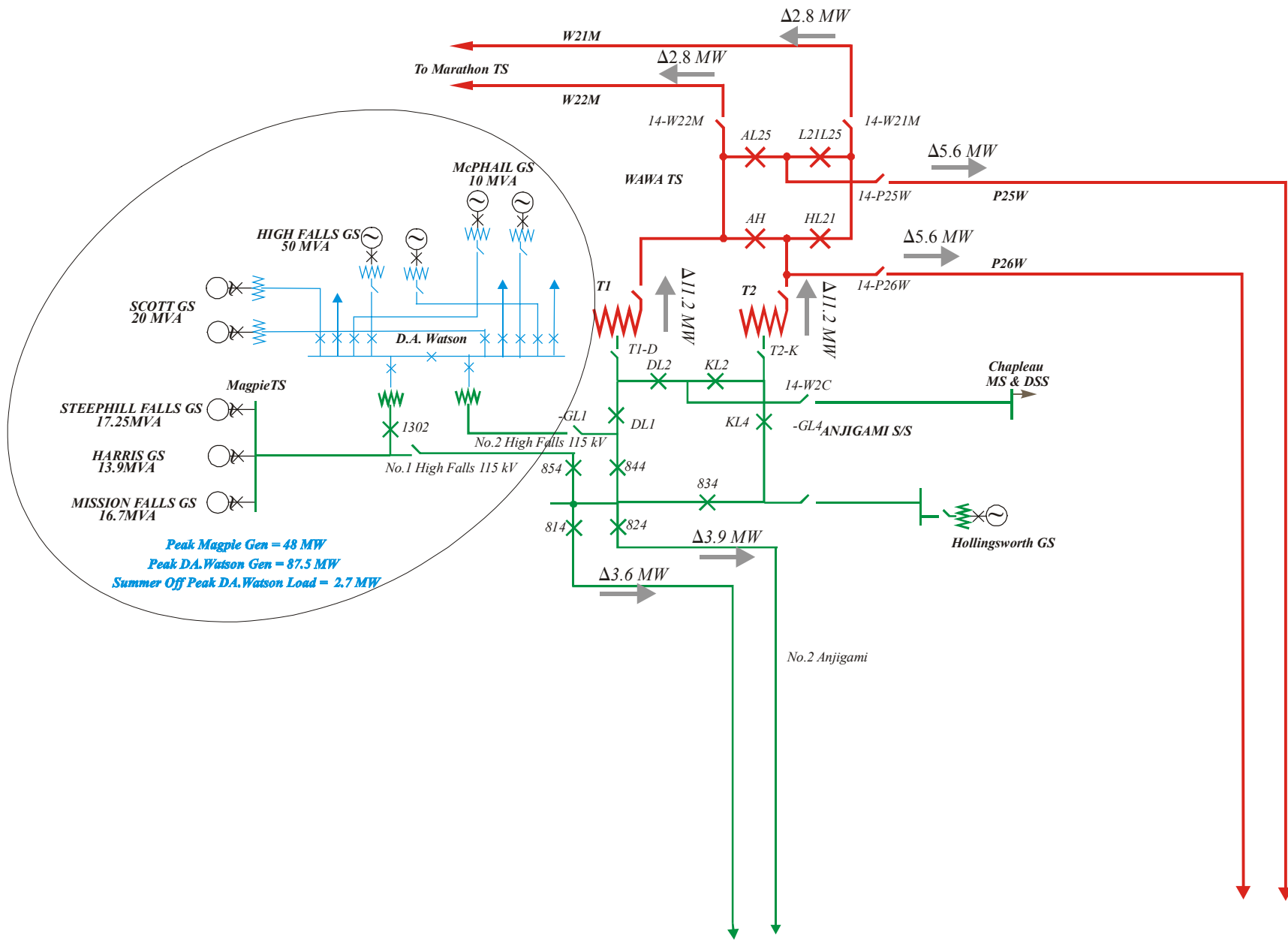
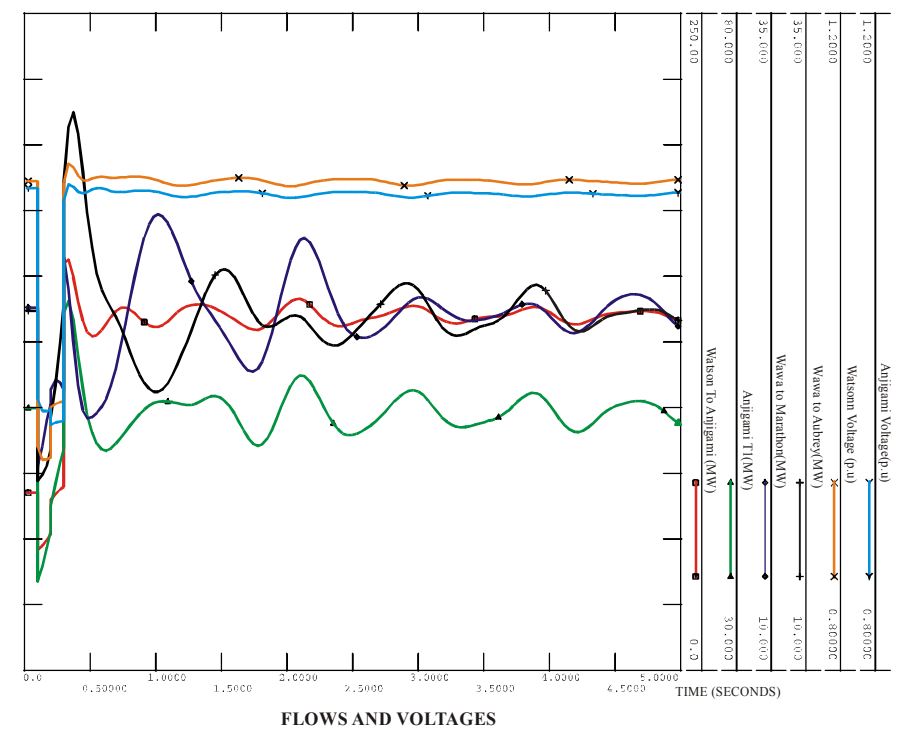
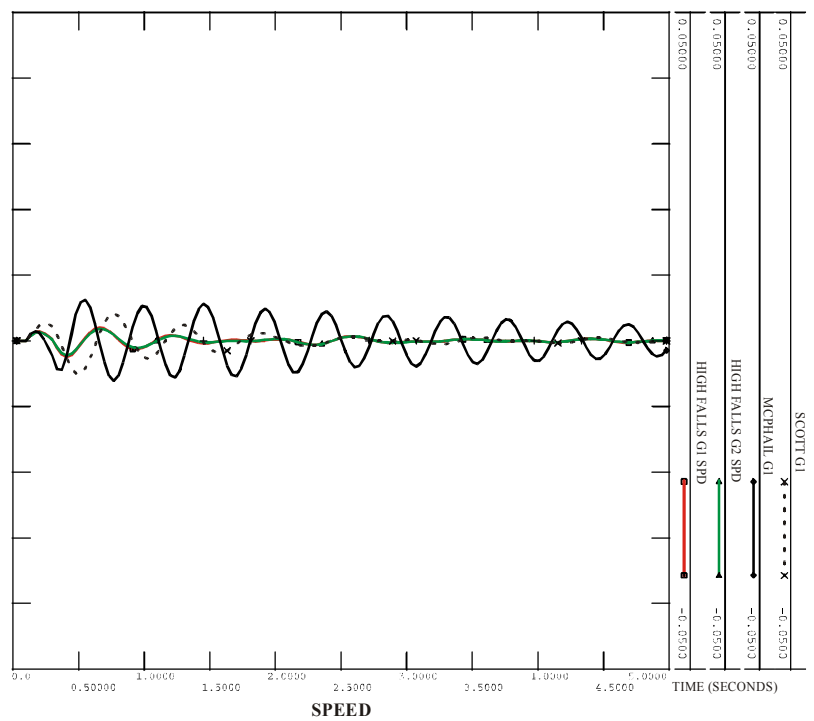
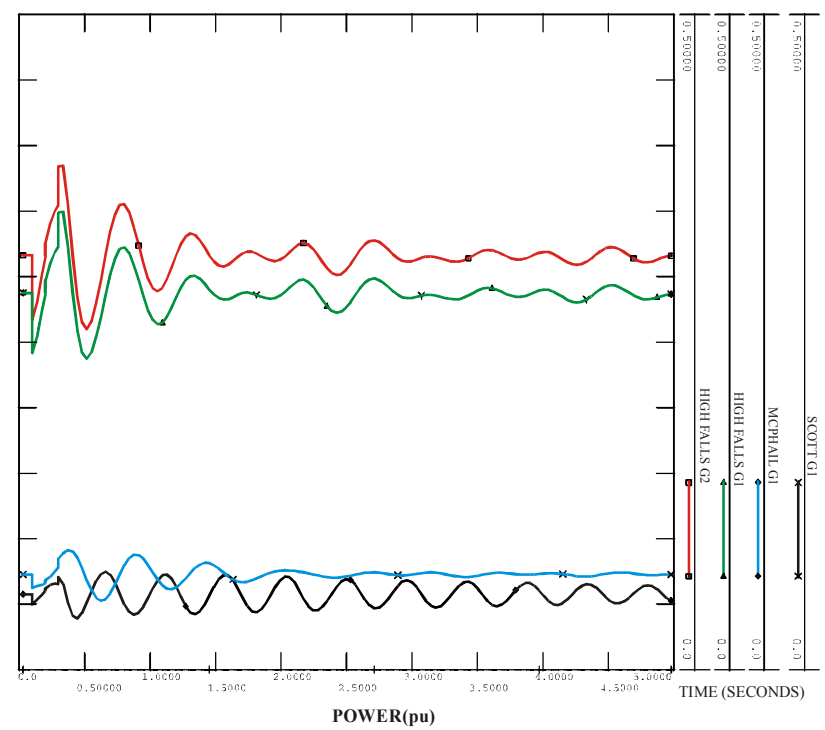
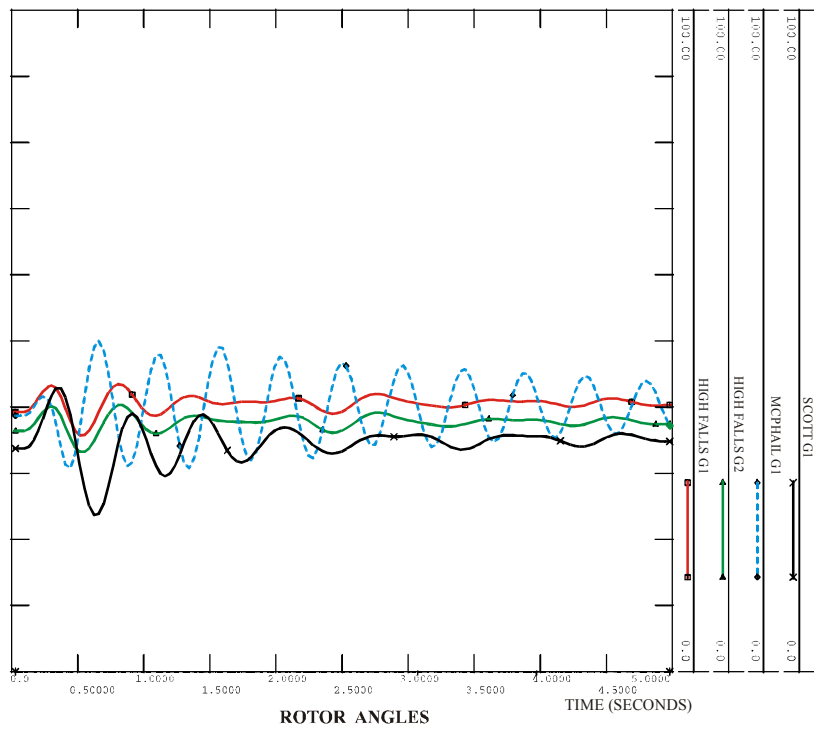


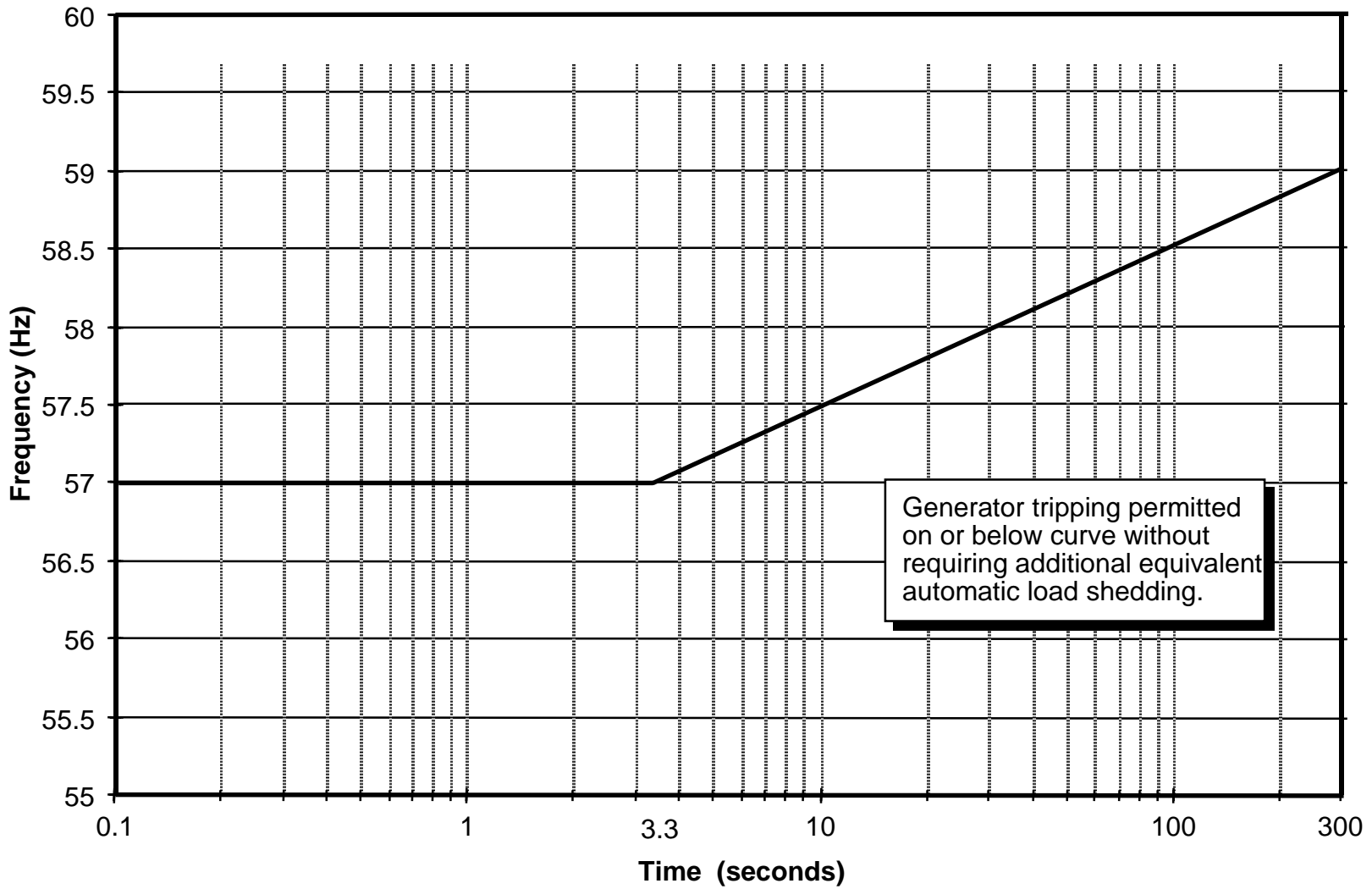
Figure 5. GLP System

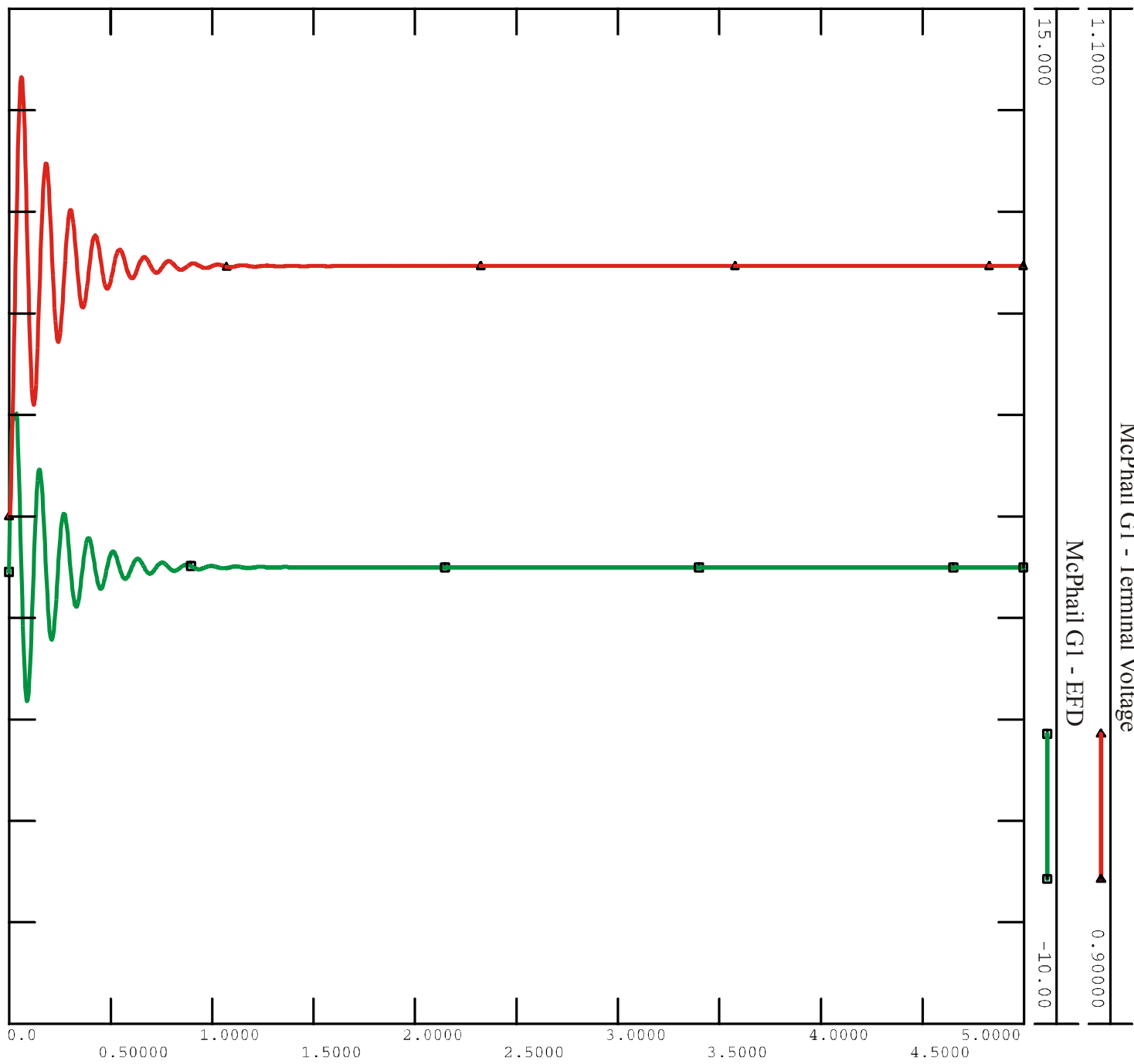


**Figure 6. Increment in Power Flows due to the Additional Generation at High Falls**



**FIGURE 7. Transient Stability Plots Loss of D.A Watson T1**





**Figure 9. Exciter Time Response Test - McPhail GS (5% ESTR)**