

CONNECTION ASSESSMENT & APPROVAL PROCESS

PRELIMINARY ASSESSMENT REPORT

Proponent: DaimlerChrysler Canada Inc.

Project: Connect the proposed Pillette Road 115/13.8kV Substation

CAA ID No. 2001-039

***Consistent Information Set Department, and
Long Term Forecasts & Assessments Department***

Final Version

Date: 16th September 2002

Preliminary Assessment Report

For the Proposal by DaimlerChrysler Canada Inc. to Connect the Proposed Pillette Road 115/13.8kV Substation

Acknowledgement

The IMO wishes to acknowledge the assistance of Hydro One in completing some of the studies for this assessment.

Disclaimers

IMO

This report has been prepared solely for the purpose of assessing whether the connection applicant's proposed connection with the IMO-controlled grid would have an adverse impact on the reliability of the integrated power system and whether the IMO should issue a notice of approval or disapproval of the proposed connection under Chapter 4, Section 6 of the Market Rules. This report has not been prepared for any other purpose and should not be used or relied upon by any person for another purpose. In particular, this report does not address any other Market-related or any commercial aspects of the connection proposal. This report has been prepared solely for use by the connection applicant and the IMO in accordance with Chapter 4, Section 6 of the Market Rules. The IMO assumes no responsibility to any third party for any use which it makes of this report. Any liability which the IMO may have to the connection applicant in respect of this report is governed by Chapter 1, Section 13 of the Market Rules. The IMO reserves the right to revise this report at any time, at its sole discretion, without notice to the connection applicant. Although the IMO will use its best efforts to advise the connection applicant of such changes, it is the responsibility of the connection applicant to ensure that the most recent version of this report is being used.

Hydro One

Special Notes and Limitations of Study Results

The results reported in this preliminary feasibility study are based on the information available to Hydro One, at the time of the study, suitable for a preliminary assessment of a new generation or load connection proposal.

The ampacity rating of Hydro One facilities are established based on assumptions used in Hydro One for power system planning studies. The actual ampacity ratings during operations may be determined in real-time and are based on actual system conditions, including ambient temperature, wind speed and facility loading, and may be higher or lower than those stated in this study.

The additional facilities or upgrades, which are required to incorporate the proposed connection, have been identified to the extent permitted by a preliminary assessment. Additional facility studies may be necessary to confirm constructability and the time required for construction. System impact or further studies at more advanced stages of the project development may identify additional facilities that need to be provided or that require upgrading.

PRELIMINARY ASSESSMENT REPORT

For the Proposal by DaimlerChrysler Canada Inc. to Connect the Proposed Pillette Road 115/13.8kV Substation

EXECUTIVE SUMMARY

This Preliminary Assessment has examined the expected impact on the IMO-controlled grid of the proposal by DaimlerChrysler Canada Inc. to connect the new Pillette Road 115/13.8kV substation.

The scheduled in-service date for the new substation is June-2004.

Connection Arrangement

It is proposed to connect the new substation, which is to be configured as a conventional DESN station, on to the existing 115kV circuits, Z1E & Z7E, between Lauzon TS and Essex TS.

Each step-down transformer is to be connected via an SF₆ circuit switcher, which is not equipped with an integral disconnect switch, and a separately mounted motorised disconnect switch.

Impact on Reliability

The proposed connection of the new substation is not expected to materially reduce the reliability of the IMO-controlled grid.

The IMO has identified concerns regarding the ability of the existing transmission facilities in the Windsor area to supply the present load and has recommended measures that would improve the situation.

It is expected that the initial phase of the proposed system enhancements will be completed before the new DaimlerChrysler substation is placed in-service in June-2004.

Windsor Area Overload Protection Scheme

The existing Windsor Area Overload Protection Scheme allows control actions to be initiated automatically to address post-contingency overloads and voltage declines. One of these control actions involves the splitting of the 115kV busbar at Essex TS. Two different options for splitting the Essex busbar are available:

- Mode 1 which results in the load at Essex TS and the loads at the Automotive Plants that are supplied from circuits E8F & E9F, being supplied from Keith TS.
- Mode 2 which results in the load at Essex TS and the loads at the Automotive Plants that are supplied from circuits E8F & E9F, being supplied from Lauzon TS.

However, because it would result in the automatic rejection of the load at Essex TS and all of the load that is supplied from circuits E8F & E9F, the existing termination arrangement at Essex TS effectively precludes the use of a Mode 1 split of the 115kV system in response to a J3E contingency.

The IMO has therefore recommended that the termination arrangement at Essex TS be modified accordingly.

Performance of the Windsor Area Transmission System

An assessment of the existing transmission facilities under peak load conditions for the summer-2002 has shown that splitting the 115kV busbar at Essex TS would address the overloading that would be expected to occur for the following contingency conditions:

- Mode 1 For a single-circuit contingency involving the 115kV circuit Z1E or Z7E
[A double-circuit contingency involving the 115kV circuits Z1E & Z7E would also result in a Mode 1 split of the 115kV busbar at Essex TS]
- Mode 2 For a single-circuit contingency involving the 115kV circuit J3E or J4E
[A double-circuit contingency involving the 115kV circuits J3E & J4E would also result in a Mode 2 split of the 115kV busbar at Essex TS]

For a contingency involving either of the 230/115kV auto-transformers at Keith TS

For a contingency involving 230kV circuit C22J, which results in the automatic loss of auto-transformer T12 at Keith TS by configuration.

- For contingencies involving one of the auto-transformers at Lauzon TS, a Mode 2 split of the 115kV system would not be a viable option because of the excessive transfers that would occur through the remaining auto-transformer.

However, while a Mode 1 split would result in substantially lower transfers, they would still exceed the 15-minute rating of the remaining auto-transformer, if the TransAlta (Windsor) generating facility were not dispatched. With the TransAlta (Windsor) facility in-service, the transfer through the remaining auto-transformer, for the present load levels, would be marginally in excess of its 10-day rating.

- Following a Mode 1 split of the 115kV system at Essex TS that occurs in response to the loss of one of the Lauzon auto-transformers, either because of an auto-transformer fault or because of a 230kV line fault, the flow on the remaining 230kV circuit, C23Z or C24Z, could also become a concern.

Since the respective sections of circuits C23Z & C24Z between Chatham TS and Sandwich Junction are equipped with dissimilar conductors, circuit C24Z is the more limiting. Therefore, following a Mode 1 split of the 115kV system in response to a contingency involving circuit C23Z or its associated auto-transformer T1, the post-contingency flow on circuit C24Z, after allowing for losses, is expected to exceed its 15-minute limited-time-rating. Similarly, for a contingency involving circuit C24Z or its associated auto-transformer T2, that also results in a Mode 1 split of the 115kV system, the post-contingency flow on circuit C23Z is expected to either exceed, or to be very close to the emergency rating of the line. With increasing load the situation will further deteriorate.

These results have been summarised in Table 1.

Conclusions & Recommendations

This Assessment has concluded that the proposed connection of the new DaimlerChrysler TS to circuits Z1E & Z7E will not materially reduce the *present* level of reliability or the load-meeting capability of the existing facilities.

However, concerns have been identified regarding the ability of the existing transmission facilities in the Windsor area to reliably supply the existing loads under contingency conditions.

Since these concerns are considered to relate to existing system deficiencies, the IMO expects that Hydro One will respond with suitable proposals that would adequately address them.

The IMO considers that the enhancement of the post-contingency transfer capability of the 115kV transmission facilities between Keith TS and Essex TS should be undertaken as soon as possible to permit a Mode 1 split of the 115kV system to be initiated in response to contingencies involving 115kV circuit J3E or J4E. Based on the present load forecast, a minimum, post-contingency emergency rating of at least 305MVA (1470A) for each circuit would be adequate for the forecast loads through to the end of the decade.

In conjunction with the proposed upgrading of circuits J3E & J4E it will also be necessary to revise the circuit terminations at Essex TS to allow a Mode 1 split of the 115kV system to be used in response to a J3E contingency.

Furthermore, since it is expected that the required increase in the emergency rating of the Keith TS to Essex TS circuits would also result in an increase in the continuous rating of these circuits, a target rating of 260MVA (1250A) has been proposed for the section of circuits J3E & J4E between Keith TS and Crawford Junction. This would be sufficient to allow the West Windsor Power facility, as well as the ATCO Project once it is placed in-service, to be fully dispatched while transfers, equal to their nameplate ratings, are being made through the two auto-transformers at Keith TS.

Once the ATCO Power facility is in-service, a *continuous* rating of 260MVA for each of the JxE circuits should be sufficient to supply all of the load that is presently supplied via circuits J3E & J4E, and Z1E & Z7E to be supplied entirely from Keith TS. Subject to acceptable voltages being maintained, this would allow the 115kV system to be split at Lauzon TS, as an alternative to Essex TS. This would be particularly beneficial under contingency conditions involving either of the auto-transformers at Lauzon TS, since it would leave only that load that is presently supplied from circuits K2Z & K6Z to be supplied by the remaining auto-transformer at Lauzon TS. It is therefore recommended that this option be investigated.

In addition to enhancing the transfer capability of the Keith TS to Essex TS Interface, consideration needs to be given to transferring some of the existing load in the Lauzon area on to another supply point and/or increasing the transfer capability of the 230kV transmission facilities into Lauzon TS together with an increase in the capacity of the auto-transformers at that location.

Need for a System Impact Assessment

Based on the results of this assessment it has been concluded that all the necessary analysis to determine the impact that the proposed DaimlerChrysler TS would have on the IMO-controlled grid has been undertaken.

A separate System Impact Assessment is therefore not considered necessary for this Project.

Customer Impact Assessment

Hydro One Networks Inc., in consultation with the IMO, has concluded that this Project will have no adverse impact on any other customers in the area, and that a formal Customer Impact Assessment is not required.

Notification of Approval of the Connection Proposal

Based on the results of this Assessment it is recommended that a *Notification of Approval for Connection* be issued for this Project.

TABLE 1 Summary of the Performance of the Windsor Area Transmission System (based on summer-2002 peak loads)		
<i>Contingency Condition</i>	<i>Mode 1 Split of the Essex 115kV busbar</i>	<i>Mode 2 Split of the Essex 115kV busbar</i>
<i>With the West Windsor Power & TransAlta (Windsor) generating facilities out-of-service</i>		
None	Transfers through the Keith auto-transformers remain within their 10-day rating. Transfers through the Lauzon auto-transformers remain within their continuous rating.	Transfers through the Keith auto-transformers remain within their continuous rating. Transfers through the Lauzon auto-transformers remain within their 10-day rating.
J3E or J4E	Emergency/15-minute rating of companion circuit exceeded	Continuous rating of companion circuit respected.
J3E & J4E <i>(Initiates a Mode 2 split of the Essex busbar)</i>	<i>Not applicable</i>	<i>No additional overloads</i>
Z1E or Z7E	Continuous rating of companion circuit respected	15-minute rating of companion circuit exceeded
Z1E & Z7E <i>(Initiates a Mode 1 split of the Essex busbar)</i>	<i>No additional overloads</i>	<i>Not applicable</i>
Auto-transformer T11 or T12 at Keith TS	15-min LTR of companion auto-transformer exceeded	Continuous rating of companion auto-transformer respected
Auto-transformer T1 or T2 at Lauzon TS	15-min LTR of companion auto-transformer exceeded.	15-min LTR of companion auto-transformer exceeded
<i>With both the West Windsor Power & TransAlta (Windsor) generating facilities in-service</i>		
None	Transfers through the Keith auto-transformers remain within their continuous rating. Transfers through the Lauzon auto-transformers remain within their continuous rating.	Transfers through the Keith auto-transformers remain within their continuous rating. Transfers through the Lauzon auto-transformers remain within their continuous rating.
J3E or J4E	Emergency/15-minute rating of companion circuit exceeded	Continuous rating of companion circuit respected
J3E & J4E <i>(Initiates a Mode 2 split of the Essex busbar)</i>	<i>Not applicable</i>	<i>No additional overloads</i>
Z1E or Z7E	Continuous rating of companion circuit respected	Emergency rating of companion circuit exceeded
Z1E & Z7E <i>(Initiates a Mode 1 split of the Essex busbar)</i>	<i>No additional overloads</i>	<i>Not applicable</i>
Auto-transformer T11 or T12 at Keith TS	10-day rating of companion auto-transformer respected	Continuous rating of companion auto-transformer respected
Auto-transformer T1 or T2 at Lauzon TS	10-day rating of companion auto-transformer exceeded	15-min LTR of companion auto-transformer exceeded

PRELIMINARY ASSESSMENT REPORT

For the New DaimlerChrysler Canada Inc. 115/13.8kV Pillette Road Substation

1. Introduction

DaimlerChrysler Canada Inc. is proposing to connect a new 115/13.8kV substation at the Pillette Road Assembly Plant in Windsor to the IMO-controlled grid.

The new substation, which is to be configured as a conventional DESN station, is to be connected to the existing double-circuit 115kV line, Z1E & Z7E, between Essex TS and Lauzon TS. This double-circuit line presently supplies the Ford Essex Engine Plant (Ford EEP) and Walker TSs Nos. 1 & 2. The TransAlta (Windsor) 65MW generation station is also connected to circuit Z1E.

The proposed in-service date for the new facility is June-2004.

2. Connection Arrangement

Diagram 1 shows the proposed configuration of the new substation and its connection on to circuits Z1E and Z7E.

The principal 230kV & 115kV transmission facilities in the Windsor area, together with the location of the new DaimlerChrysler Substation, are shown in Diagram 2.

Each transformer at the new Substation is to be switched via a 115kV SF₆ circuit switcher that consists of a separate SF₆ 'puffer unit' without an integral disconnect switch, and a series connected 115kV motorised disconnect switch.

The fault interrupting capability of the circuit switcher is 40kA symmetrical and 64kA asymmetrical, while its continuous rating is 1200A.

The continuous rating of the motorised disconnect switch is 600A. (~125MVA at 120kV)

Both the circuit switcher and the disconnect switch are rated for a continuous voltage of 138kV

Each of the two 30/40/50MVA Wye : Delta step-down transformers is to be equipped with under-load tap-changers, with a range of +/-15% in 18 steps. The HV winding is to be solidly grounded, while the LV winding is to be grounded via a 60 ohm zig-zag transformer with a continuous rating of 20A and a 10sec. rating of 400A. The transformer impedance is 10% on a rating of 30MVA.

Each transformer is to be equipped with a 3000A 1000MVA 13.8kV breaker and connected to a 3000A 1000MVA 13.8kV busbar. An identical breaker is also to be installed in the bus-tie position. All three LV breakers are to be operated normally-closed.

Provision is to be included in the new substation layout for a total of twenty-four feeder positions, twelve on each busbar.

Under-frequency load-shedding facilities are to be installed to trip selected LV feeders in accordance with Market Rule - 10.4.6 of Chapter 5, which requires at least 30% of a customer's peak demand to be available for automatic rejection.

Since the DaimlerChrysler facility that is to be supplied from the new Pillette Road Substation is classified as an 'industrial customer', it is exempt from the requirement to install facilities to allow voltage reductions of 3% & 5% to be initiated remotely in order to achieve load reductions during periods when limited supply resources are available.

Operating Voltage Range

Figure 1, which shows the voltages that were recorded on the 115kV busbar at Lauzon TS during 2001, provides an indication of the variation in voltage that should normally be expected at the new DaimlerChrysler facility.

However, it should also be noted that in accordance with the Market Rules (Appendix 4.1), voltages on the 115kV system are only required to be maintained within the range 113kV to 127kV. Equipment that is installed within the new facility should therefore be capable of operating satisfactorily over this range.

Fault Rating of Equipment & Fault Clearance

The Transmission Code requires facilities that are to be installed on the 115kV system to be rated at 50kA.

Since the circuit switchers that are to be installed at the new substation is only rated at 40kA (symmetrical) they would not comply with the Code. However, a review of recent fault level studies has shown that this rating would be adequate for fault interrupting duty for the present system, as well as when the new Brighton Beach generating facility that ATCO Power is present constructing at Keith TS is in-service.

Should new generating facilities be added to the system or new transmission facilities be installed then these could increase the fault level beyond the rating of the circuit switchers. At that time, DaimlerChrysler would be required to replace the circuit switchers with higher-rated devices, or to restrict their operation to normal switching duties and also for back-up fault clearance in the event of an LV breaker failure condition.

Transformer faults at the new substation are to be cleared via the respective 115kV circuit switcher. Simultaneous operation of the motorised disconnect switch is also to be initiated. In the event that the circuit switcher should fail to operate, remote trip signals are to be sent to the terminal stations to trip the appropriate 115kV circuit.

Line faults are to be isolated using the associated 115kV circuit switcher via a transfer trip signal from the terminal stations.

The installation must also be fully compliant with the provisions of the Transmission System Code, and will therefore require that the remote trip and transfer trip protection signals be duplicated.

Load at the New Substation

The peak load at the new substation is expected to be approximately 30MVA initially, increasing to approximately 36MVA within five years. This includes the existing load of approximately 12MVA that is presently supplied from Walker TS No. 2.

3. Power Factor

Reference 1 of Appendix 4.3 of the Market Rules requires the power factor for Connected Wholesale Customers and Distributors to be within the range of 0.90 lagging and 0.90 leading as measured at the defined meter point. Since the defined meter point is required to be at a voltage greater than 50kV, this means that the power factor at the 115kV terminals of the new MTS will be required to exceed 0.90 lagging.

It is also recommended that the layout of the proposed new substation should be modified to include provision for the future installation of shunt capacitor banks on the expectation that these will be required to meet the power factor requirements of the Market Rules.

4. Impact on Reliability

The proposed connection of the new DESN station is not expected to materially reduce the reliability of the IMO-controlled grid.

However, as discussed later in this Assessment, the IMO has concerns regarding the ability of the existing transmission facilities in the Windsor area to supply the present load and has therefore recommended that measures be implemented as soon as possible to improve the situation.

It is expected that the initial phase of the proposed system enhancements will be completed before the new DaimlerChrysler substation is placed in-service in June-2004.

5. Windsor Area Overload Protection Scheme

The existing Windsor Area Overload Protection Scheme consists of the following components:

- facilities that detect overloads on either of the two auto-transformers at Keith TS or on circuits Z1E or Z7E at Lauzon TS. These facilities can be armed to initiate splitting of the 115kV system between Keith TS and Lauzon TS, at Essex TS.

Diagram 3 shows the two alternatives available for splitting the 115kV system at Essex TS

- facilities that detect a loss of connectivity between the 230kV and 115kV systems at Lauzon TS. These facilities can be armed to initiate tripping of circuits K2Z and K6Z to reject all of the load at Kingsville TS, Tilbury West DS and Tilbury TS.
- facilities that detect excessive voltage declines at Kingsville TS. These facilities can be used to initiate staged load rejection at that TS following pre-defined time delays to allow auto-reclosure to be attempted. [Presently, if a voltage of 106kV or below should be sustained for at least 7 seconds, then the Stage 1 load rejection would be initiated. If this minimum voltage should be sustained for a further 3 seconds following operation of the Stage 1 load rejection, then Stage 2 load rejection would be initiated.]

Alternatives for splitting the Windsor Area 115kV system at Essex TS

The two alternative modes for splitting the Windsor area 115kV system are as follows:

Mode 1: This results in the following distribution of loads between the two supply points -

From Keith TS Crawford TS, Ford Aluminum, Essex TS and all the automotive plant loads supplied from circuits E8F & E9F (circuit E8F becomes idle)

From Lauzon TS Ford EEP, Walker TSs Nos. 1 & 2 and the new DaimlerChrysler load.

Mode 2: This results in the following distribution of loads between the two supply points -

From Keith TS Crawford TS & Ford Aluminum

From Lauzon TS Ford EEP, Walker TSs Nos. 2 & 2, Essex TS, the new DaimlerChrysler load, and all the automotive plant loads supplied from circuits E8F & E9F

The intent of the portion of the Scheme that initiates splitting of the 115kV system at Essex TS is to eliminate any through-flows on the 115kV system between Keith TS to Lauzon TS that would contribute to post-contingency overloading of the 115kV circuits or the auto-transformers at Keith TS.

Limitations on Employing a Mode 1 Split of the 115kV System

Apart from the existing thermal limitations of circuits J3E & J4E, which, as discussed later, seriously restrict the use of a Mode 1 split of the 115kV system, the existing termination arrangement at Essex TS prevents the deployment of a Mode 1 split in response to a J3E contingency.

Diagram 4 shows the effect on the existing system configuration, of a J3E contingency, followed by a Mode 1 split of the 115kV system. Breakers L3L4 & L3L9 would open initially in response to the J3E contingency. Breakers L1L8 & L1L9 and L4L7 & L7L8 would then open to isolate circuits Z1E and Z7E, respectively, from the loads at Essex TS and the automotive loads on circuits E8F & E9F: to achieve the required Mode 1 Split.

With the present termination arrangement at Essex TS, this switching sequence would end up rejecting all the load at Essex TS, together with that at the automotive plants supplied from circuits E8F & E9F.

Diagram 5 shows the existing termination arrangement at Essex TS and the revisions that would need to be made to allow a Mode 1 split of the 115kV system to be initiated in response to a J3E contingency. The proposed rearrangement of the 115kV busbar would result in each of the ExF circuits being directly adjacent to one of the JxE circuits. In the event that one of the JxE circuits experiences a contingency, the companion circuit would then be available to supply the automotive loads via the remaining ExF circuit.

ATCO Project at Keith TS

The Assessment that was performed for the new generation facilities that ATCO Power is proposing to install at Keith TS determined that they would contribute to increased transfers through the 115kV, particularly under contingency conditions.

The enhancement of the existing Windsor Area Overload Protection Scheme to allow generation rejection and/or the splitting of the Windsor area 115kV system to be initiated in response to a number of discrete contingency conditions was therefore stipulated as an IMO requirement for the connection of this Project to the IMO-controlled grid.

6. Loads in the Windsor Area

Table 1 summarises the load forecast for those loads in the Windsor area that are supplied directly from the following 115kV circuits:

- circuits J3E & J4E between Keith TS and Lauzon TS
- circuits Z1E & Z7E between Lauzon TS and Essex TS
- circuits E8F & E9F radially connected to Essex TS

This shows an existing peak load of approximately 440MVA that is forecast to increase to approximately 500MVA by the end of the decade.

Table 2 shows the subsequent distribution of these loads on to circuits J3E & J4E at Keith TS, and on to circuits Z1E & Z7E at Lauzon TS, following the splitting of the 115kV system in accordance with the two options available through the Windsor Area Overload Protection Scheme.

Furthermore, since additional load is also supplied from the 115kV busbar at Keith TS via transformer T1, and from circuits K2Z & K6Z from Lauzon TS (Kingsville TS, Tilbury West DS & Tilbury TS), the transfers through the respective 230/115kV auto-transformers would be higher. These transfers, which assume zero output from the TransAlta facility (70MW), the West Windsor Power facility (118MW), or the 115kV-connected portion of the ATCO Power facility (180MW commencing in late-2004) are shown in Table 3.

7. Thermal Rating of Transmission Facilities

Table 4 shows the thermal ratings under summer conditions - 30°C ambient and with a wind speed of 4km/hr - for the following facilities in the Windsor area:

- 230kV circuits C21J & C22J, and C23Z & C24Z
- 115kV circuits J3E & J4E, and Z1E & Z7E, and
- 230/115kV auto-transformers at Keith TS and Lauzon TS.

The continuous ratings for the 230kV and 115kV circuits assume a maximum conductor operating temperature of 93°C, while the emergency rating assumes an operating temperature of 127°C, or the conductor sag temperature if this is lower.

The 15-minute limited-time-rating corresponds to the conductor sag temperature and assumes a pre-contingency loading of 75% of the emergency rating of the circuit.

8. *Post-contingency Transfers*

As discussed in Section 5, the existing Windsor Area Overload Protection Scheme allows splitting of the 115kV system at Essex TS for overloads on either of the 230/115kV auto-transformers at Keith TS or on 115kV circuits Z1E or Z7E, detected at Lauzon TS.

The Connection Assessment for the ATCO Project, that is presently under construction at Keith TS, identified the enhancement of the existing Scheme as a requirement for the connection of this facility to the IMO-controlled grid. The enhancements required were to allow splitting of the 115kV system to be initiated for contingencies involving the following transmission facilities:

- 230kV circuit C21J
- 115kV circuit J3E
- 115kV circuit Z1E
- 230/115kV auto-transformer T11 at Keith TS
- The Ontario-Michigan Interconnection J5D
- 230kV circuit C22J
- 115kV circuit J4E
- 115kV circuit Z7E
- 230/115kV auto-transformer T11 at Keith TS

For the purpose of this assessment, it has been assumed that splitting of the 115kV system would also be possible for contingencies involving the following transmission facilities:

- 230kV circuit C23Z
- 230/115kV auto-transformer T1 at Lauzon TS
- 230kV circuit C24Z
- 230/115kV auto-transformer T2 at Lauzon TS

8.1 *Distribution of the Windsor Area Loads Following a Split of the 115kV System*

In response to the contingencies listed above, it has been assumed that for at least some of the anticipated operating conditions, splitting of the Windsor area 115kV system at Essex TS will be necessary to address the expected overloading.

Diagrams 6 & 7 show the distribution of the local loads for the summer-2002 and the resulting flows at Keith TS and Lauzon TS, excluding losses, for a Mode 1 and Mode 2 split of the Windsor area 115kV system, respectively.

The flow distributions shown in these Diagrams assume that both the West Windsor Power facility and the TransAlta (Windsor) facility are either out-of-service or not dispatched.

If the thermal ratings that are given in Table 4 are compared with the flows shown in these Diagrams, the following conclusions can be drawn:

[For the purpose of this assessment, it has been assumed that the terminations of circuits E8F and Z7E at Essex TS have been interchanged, as discussed in Section 5, to allow a Mode 1 split to be employed for a J3E contingency.]

8.1.1 For the 115kV Transmission Circuits

i. For a *Mode 1* split of the 115kV system (Diagram 6) -

- For a contingency involving circuit J3E or J4E, under *existing* peak load conditions, the post-contingency flow on the companion circuit would exceed its 15-minute limited-time-rating (for a J4E contingency) or its emergency rating (for a J3E contingency).

<i>Contingency</i>	<i>Critical Flow</i>	<i>Flow</i> (assuming no losses)	<i>Rating</i>	
			<i>Emergency</i>	<i>15-min LTR</i>
J3E or J4E	Companion circuit	264MVA	234MVA (J3E) 219MVA (J4E)	305MVA (J3E) 245MVA (J4E)

- For a contingency involving circuit Z1E or Z7E, under *existing* peak load conditions, the post-contingency flow on the companion circuit would remain within its continuous rating.

<i>Contingency</i>	<i>Critical Flow</i>	<i>Flow</i> (assuming no losses)	<i>Rating</i>
			<i>Continuous</i>
Z1E or Z7E	Companion circuit	175MVA	204MVA

ii. For a *Mode 2* split of the 115kV system (Diagram 7) -

- For a contingency involving circuit J3E or J4E, the post-contingency flow on the companion circuit would remain within its continuous rating for the loads that have been forecast through to 2010.

<i>Contingency</i>	<i>Critical Flow</i>	<i>Flow</i> (assuming no losses)	<i>Rating</i>
			<i>Continuous</i>
J3E or J4E	Companion circuit	89MVA (2002) 97MVA (2010)	183MVA

- For a contingency involving circuit Z1E or Z7E, under *existing* peak load conditions, the post-contingency flow on the companion circuit would exceed its 15-minute limited-time-rating, even before accounting for losses.

While the situation would improve with the TransAlta (Windsor) generating facility in-service, the post-contingency flow on the companion circuit would still exceed its emergency rating.

<i>Contingency</i>	<i>Critical Flow</i>	<i>Flow</i>	<i>Rating</i>	
			<i>Emergency</i>	<i>15-min LTR</i>
Z1E or Z7E	Companion circuit	<i>With TransAlta out-of-service</i> 350MVA (no losses) 368MVA (+ 5% losses)	262MVA	305MVA
		<i>With TransAlta in-service</i> 280MVA (no losses) 294MVA (+ 5% losses)		305MVA

8.1.2 For the 230/115kV Auto-transformers at Keith TS and Lauzon TS

i. For a *Mode 1* split of the 115kV system (Diagram 6) -

- For a Mode 1 split of the 115kV system with all elements in-service, that is initiated to limit excessive through-flows. Following the split, the resulting transfers through the auto-transformers at Keith TS and Lauzon TS when neither of the Windsor area generating facilities is dispatched, would be as follows:

At Keith TS The flows through the two auto-transformers would exceed their continuous rating, but remain within their 10-day rating.

At Lauzon TS The flows through the two auto-transformers would remain within their continuous rating.

- A Mode 1 split of the 115kV system in response to a contingency involving either of the 230/115kV auto-transformers at Keith TS would result in transfers that would exceed the 15-minute LTR of the remaining auto-transformer at Keith TS, assuming no generation capacity is in-service and ignoring losses:

<i>Contingency</i>	<i>Critical Flow</i>	<i>Flow</i> (assuming no losses)	<i>Rating</i>	
			<i>2-hour</i>	<i>15-min LTR</i>
Keith auto-transformer	Companion auto-transformer	289MVA	195MVA (T11) 167MVA (T12)	233MVA (T11) 192MVA (T12)

- A Mode 1 split of the 115kV system in response to a contingency involving either of the 230/115kV auto-transformers at Lauzon TS, with no generation capacity in-service and ignoring losses, would result in a transfer that would remain within the 15-minute LTR of the remaining auto-transformer at Lauzon TS. However, once losses have been factored in, the transfer is expected to exceed the 15-minute LTR of the auto-transformer.

While the situation would improve with the TransAlta (Windsor) generating facility in-service, the post-contingency flow on the companion auto-transformer would be expected to marginally exceed its 10-day rating, after accounting for losses.

<i>Contingency</i>	<i>Critical Flow</i>	<i>Flow</i>	<i>Rating</i>		
			<i>10-day</i>	<i>2-hour</i>	<i>15-min LTR</i>
Lauzon auto-transformer	Companion auto-transformer	<i>With TransAlta out-of-service</i>	297MVA	326MVA	364MVA
		351MVA (no losses)			
		369MVA (+ 5% losses)	297MVA	326MVA	364MVA
		<i>With TransAlta in-service</i>			
281MVA (no losses)	297MVA	326MVA	364MVA		
299MVA (+ 5% losses)					

ii. For a *Mode 2* split of the 115kV system (Diagram 5) -

- For a Mode 2 split of the 115kV system with all elements in-service, that is initiated to limit excessive through-flows. Following the split, the resulting transfers through the auto-transformers at Keith TS and Lauzon TS when neither of the Windsor area generating facilities is dispatched, would be as follows:

- At Keith TS The flows through the two auto-transformers would remain within their continuous rating.
- At Lauzon TS The flows through the two auto-transformers would exceed their continuous rating, but remain within their 10-day rating.

[i.e. A reversal of the loading situation for a Mode 1 split of the 115kV system.]

- A Mode 2 split of the 115kV system in response to a contingency involving either of the 230/115kV auto-transformers at Keith TS, with no generation capacity in-service and ignoring losses, would result in transfers that would remain within the continuous rating of the remaining auto-transformer at Keith TS.

<i>Contingency</i>	<i>Critical Flow</i>	<i>Flow</i> (assuming no losses)	<i>Rating</i>	
			<i>Continuous</i>	
Keith auto-transformer	Companion auto-transformer	114MVA	144MVA (T11)	131MVA (T12)

- A Mode 2 split of the 115kV system in response to a contingency involving either of the 230/115kV auto-transformers at Lauzon TS, with no generation capacity in-service and also ignoring losses, would result in transfers that would be well in excess of the 15-minute LTR of the remaining auto-transformer at Lauzon TS. Even with the TransAlta (Windsor) generating facility in-service, the transfer through the companion auto-transformer would still be well in excess of its 15-minute LTR.

<i>Contingency</i>	<i>Critical Flow</i>	<i>Flow</i> (assuming no losses)	<i>Rating</i>	
			<i>2-hour</i>	<i>15-min LTR</i>
Lauzon auto-transformer	Companion auto-transformer	526MVA	326MVA	364MVA

8.1.3 For the 230kV Transmission Facilities

Reference to Diagrams 6 & 7 shows that, should a single-circuit contingency occur involving one of the 230kV circuits in the Windsor area and it results in the subsequent overloading of the auto-transformers at the other 230kV infeed into the Windsor area, the 115kV system would need to be split as follows:

i. For a contingency involving 230kV circuit C23Z or C24Z

Should this contingency result in the subsequent overloading of the auto-transformers at Keith TS due to the high pre-contingency flows through these units due to any combination of the following operating scenarios, then a Mode 1 split of the 115kV system would need to be initiated.

- high levels of transfers into Ontario over the J5D Interconnection
- the generating facilities at West Windsor Power and/or TransAlta (Windsor) out-of-service

A Mode 1 split of the 115kV system would impose the *maximum* amount of the Windsor area load on to the two auto-transformers at Keith TS while maintaining the transfers to within their 10-day ratings. (After accounting for system losses, their continuous ratings are expected to be exceeded.)

A Mode 1 split would also impose the *minimum* amount of Windsor area load on the remaining Lauzon auto-transformer. However, as shown earlier, the transfer through the remaining auto-transformer whenever the TransAlta (Windsor) facility is out-of-service, would exceed its 15-minute LTR, once losses have been accounted for.

With the TransAlta Project in-service, the post-contingency transfer through the remaining auto-transformer would be expected to marginally exceed its 10-day rating, after accounting for losses.

<i>Contingency</i>	<i>Critical Flow</i>	<i>Flow</i>	<i>Rating</i>		
			<i>10-day</i>	<i>2-hour</i>	<i>15-min LTR</i>
C23Z or C24Z Results in loss of associated Lauzon auto-transformer	Companion auto-transformer	<i>With TransAlta out-of-service</i>	297MVA	326MVA	364MVA
		351MVA (no losses)			
		369MVA (+ 5% losses)	297MVA	326MVA	364MVA
		<i>With TransAlta in-service</i>			
281MVA (no losses)	297MVA	326MVA	364MVA		
		299MVA (+ 5% losses)	297MVA		

It should also be noted that for a Mode 1 split of the 115kV system in response to a contingency involving the 230kV circuit C23Z, the transfer on the companion circuit C24Z, even with the TransAlta (Windsor) facility in-service, would exceed its 15-minute limited-time-rating.

<i>Contingency</i>	<i>Critical Flow</i>	<i>Flow</i>	<i>Rating</i>	
			<i>Emergency</i>	<i>15-min LTR</i>
230kV Circuit C23Z	Companion 230kV circuit C24Z	<i>With TransAlta out-of-service</i>	440MVA	495MVA
		571MVA (no losses)		
		600MVA (+ 5% losses)		
		<i>With TransAlta in-service</i>		
		501MVA (no losses)		
		530MVA (+ 5% losses)		

ii. For a contingency involving 230kV circuit C21J or C22J

A contingency involving the 230kV circuit C22J would remove auto-transformer T12 at Keith TS, by configuration. Should this result in the 15-minute limited-time-rating of auto-transformer T11 being exceeded, this would initiate splitting of the Windsor area 115kV system.

For this situation a Mode 2 split would be required to minimise the amount of the Windsor area load that would be supplied via the remaining auto-transformer at Keith TS.

With the TransAlta (Windsor) facility out-of-service, this would result in a transfer through the two auto-transformers at Lauzon TS that would exceed their combined continuous rating, but would be expected to remain within their combined 10-day rating, after allowing for losses. However, should the losses, or increases in the local loads, raise the transfers above the 10-day rating so that the 2-hour rating applies, then, in the event of a permanent line fault, this would still provide sufficient time to restore the auto-transformer T12 at Keith TS, to service.

8.2 Voltage Declines at Kingsville TS

Should a Mode 2 split of the Windsor area 115kV system be initiated in response to a contingency involving one of the 115kV circuits J3E or J4E, or one of the two auto-transformers at Keith TS, then the subsequent transfer through Lauzon TS could be sufficient to depress the voltages at Kingsville TS below the 106kV threshold that would trigger load rejection.

It should be noted that restoration of this load would not be possible until the Windsor area is no longer being operated split.

Load flow analysis has shown that, for the condition with the TransAlta (Windsor) facility out-of-service, the voltage at Kingsville TS following a Mode 2 split of the 115kV system, would be approximately 106kV with the voltages at Chatham TS and Lauzon TS at 242kV and 220kV, respectively. This suggests that the maximum transfer that could be made through the two auto-transformers at Lauzon TS without triggering load rejection at Kingsville TS would be approximately 530MVA. This also assumes that the combined load at the Lauzon DESN stations is approximately 220MVA.

The situation would be expected to improve with the TransAlta (Windsor) facility in-service, since it would reduce the transfers through Lauzon TS, while also providing voltage support at Essex TS.

9. Summary of the Requirements for Splitting the Windsor area 115kV System

Table 5 summarises the performance of the Windsor area transmission system for each of the two Modes for splitting the 115kV system in response to different contingency conditions.

Those cells that have been shaded in this Table indicate conditions where the extent of the post-contingency overloading would be unacceptable.

Inspection of this Table indicates that the Windsor area 115kV system will need to be split, as follows, in response to the various contingency conditions involving the 115kV and 230kV transmission facilities in the Windsor area:

9.1 A Mode 1 Split of the Windsor area 115kV system

A Mode 1 split of the 115kV busbar at Essex TS is expected to be required for the following contingency conditions:

- i. A single-circuit contingency involving either of the 115kV circuits Z1E or Z7E
- ii. A double-circuit contingency involving 115kV circuits Z1E & Z7E would also result in a Mode 1 split of the 115kV busbar at Essex TS, while also rejecting 218MVA (summer-2002) of directly-connected load.

Comments on the effect of a split of the Essex busbar for each contingency condition:

Contingency i. With no generation capacity in-service at the TransAlta (Windsor) facility, the flow on the companion circuit under peak load conditions, with losses ignored, would remain within its continuous rating of 204MVA for the forecast load until about 2007. However, once losses have been taken into account, the continuous rating of the remaining circuit is expected to be exceeded by the flows for the forecast load for the year 2004.

With the TransAlta (Windsor) facility in-service, the flows would be expected to remain within the continuous rating of the companion circuit for the load levels that have been forecast through to the end of the decade.

Contingency ii. This contingency condition would result in the automatic rejection of 218MVA of load, while also resulting in a Mode 1 split of the 115kV busbar at Essex TS.

9.2 A Mode 2 Split of the Windsor area 115kV system

A Mode 2 split of the 115kV busbar at Essex TS is expected to be required for the following contingency conditions:

- i. A single-circuit contingency involving either of the 115kV circuits J3E or J4E
- ii. A contingency involving one of the 230/115kV auto-transformers at Keith TS
- iii. A single-circuit contingency involving the 230kV circuit C22J (which would remove auto-transformer T12 at Keith TS from service, by configuration)

- iv. A double-circuit contingency involving 115kV circuits J3E & J4E would also result in a Mode 2 split of the 115kV busbar at Essex TS, while also rejecting 89MVA (summer-2002) of directly-connected load.

Comments on the effect of a split of the Essex busbar for each contingency condition:

- Contingency i. Regardless of the status of the West Windsor Power facility, the flow on the companion 115kV circuit under peak load conditions would remain within its continuous rating.
- Contingencies ii. & iii. During those periods when transfers are being made into Ontario over the J5D Interconnection and/or the generating facilities at West Windsor Power and at the TransAlta (Windsor) facility are out-of-service, a Mode 2 split of the 115kV system is expected to be necessary in response to these contingencies to reduce the transfers through the remaining auto-transformer at Keith TS.
- Contingency iv. Since this contingency condition would result in the automatic rejection of 89MVA (summer 2002) of directly-connected load at Crawford TS, the transfer through the auto-transformers at Keith TS would correspond to the remaining load at Ford Aluminum. Or, if the West Windsor Power facility were in-service, then there would be a net transfer to the 230kV system.

9.3 Auto-transformers at Lauzon TS

Since a Mode 2 split of the 115kV system in response to a contingency involving one of the auto-transformers at Lauzon TS results in transfers through the remaining auto-transformer that are well in excess of its 15-minute LTR, this split is not considered to be a viable option.

However, while a Mode 1 split would result in a greater portion of the Windsor area load being supplied from the auto-transformers at Keith TS, the load that would still have to be supplied via the remaining auto-transformer at Lauzon TS would still exceed its 15-minute LTR, if the TransAlta (Windsor) generating facility is out-of-service.

With the TransAlta (Windsor) generating facility in-service, the post-contingency flow through the remaining auto-transformer at Lauzon TS would only be marginally in excess of its 10-day rating. However, the situation will become more critical as the peak load for the immediate area increases in future years.

10. System Deficiencies

This review of the performance of the Windsor area system under peak load conditions for the current year shows that contingencies involving the transmission facilities associated with the Keith supply point would require a Mode 2 split of the 115kV system to avoid overloading the remaining facilities at Keith TS. However, a Mode 2 split of the 115kV system would result in an excessive amount of load being transferred to the Lauzon supply point, resulting in the auto-transformers at Lauzon TS being loaded beyond their continuous rating (but within their 10-day rating). In addition, the excessive amount of load that would be supplied via the 230kV circuits into Lauzon TS and by the Lauzon auto-transformers could initiate load rejection at Kingsville TS in response to depressed voltages on that 115kV busbar.

It would therefore be preferable if a Mode 1 split could be used to address the contingency conditions associated with the transmission facilities at Keith TS. However, this would require the *emergency* rating of circuits J3E & J4E to be increased to the ratings shown below, which would be adequate to meet the forecast loads through to the end of the decade, including losses (289MVA + 15MVA losses).

While an increase in the continuous rating for these circuits is not considered to be as critical, achieving the values shown below would allow the maximum transfers through the two auto-transformers at Keith TS (2 x 125MVA), together with the full output of the ATCO Power (180MVA) and West Windsor Power (115MVA) generating facilities, to be accommodated, after allowing for the local 115kV load at Keith TS (25MVA):

Proposed Ratings for 115kV Circuits J3E & J4E			
<i>Circuit</i>	<i>Section</i>	<i>Emergency Rating</i>	<i>Continuous Rating</i>
J3E & J4E	Keith TS to Crawford Junction	>305MVA (1470A at 120kV)	~260MVA (1250A at 120kV)
	Crawford Junction to Essex TS	>225MVA (1080A at 120kV)	~220MVA (1060A at 120kV)

It is worth noting from Table 1 that the forecast loads for the year 2010, that are to be supplied via circuits J3E & J4E from Keith TS, and via circuits Z1E & Z7E from Lauzon TS, total 503MVA (plus ~25MVA losses). If the initial section of circuits J3E & J4E from Keith TS were to be uprated to a continuous rating of at least 260MVA, as proposed in the above Table, then this would allow all of this load to be supplied from Keith TS, assuming that acceptable voltages levels can be maintained.

This would be particularly beneficial under contingency conditions involving one of the 230/115kV auto-transformers at Lauzon TS, since with a suitable rearrangement of the 115kV terminations at Lauzon TS, the 115kV system could be split at that location.

This would then leave only the load that is presently supplied from circuits K2Z & K6Z (forecast to be 203MVA in 2010) to be supplied via the remaining auto-transformer at Lauzon TS.

If the 115kV circuits J3E & J4E were to be uprated to the emergency ratings that have been proposed, the subsequent bottleneck on the system could then become the two auto-transformers at Keith TS, particularly during those periods when the generating facilities at Keith TS are not dispatched.

However, with the development of the ATCO Project (expected to be placed in-service in Q3-2004), it would be reasonable to expect at least one of the two generating facilities that would then be connected to the 115kV busbar at Keith TS, to be in-service.

With circuits J3E & J4E uprated and with the new ATCO generating facility in-service, it is expected that there will be more occasions when it will be possible to avoid initiating a Mode 1 split of the 115kV system. The 115kV system would then continue to be operated closed following a contingency involving either of the auto-transformers at Keith TS or either of the Keith TS to Essex TS 115kV circuits.

However, there may still be situations where splitting the 115kV system would be necessary, and with the Jx E circuits uprated, a Mode 1 split could be used rather than a Mode 2 split, as is presently the case. This would also be expected to allow more generation capacity to be maintained in-service post-contingency, avoiding the need to initiate generation rejection.

As mentioned in Section 5, it will also be necessary to revise the termination arrangement of the circuits at Essex TS, so that a Mode 1 split of the 115kV system can be initiated following a contingency involving circuit J3E. This will require the terminations for circuits E8F and Z7E to be interchanged.

In addition to the proposed uprating the two circuits between Keith TS and Essex TS, it would be necessary to install a cross-tripping scheme to initiate a Mode 1 split of the Essex 115kV busbar in response to the following contingency conditions:

- a single-circuit contingency involving either of the 115kV circuits J3E or J4E
- a contingency involving either of the 230/115kV auto-transformers at Keith TS
- a contingency involving 230kV circuit C21J, for those occasions when circuit C22J is out-of-service. (Since circuit C22J has an in-line breaker, a contingency involving this circuit would not result in the loss of the associated auto-transformer.)

To comply with the IMO criteria, connectivity-based logic would need to be used to detect the contingencies listed above.

[These cross-tripping facilities would be the same as those that have been identified for the incorporation of the ATCO Power Project.]

While the proposed uprating of circuits J3E & J4E would address the most immediate problems in the Windsor area, there could be occasions, particularly under conditions when high transfers are being made to Michigan across the J5D Interconnection, when the transfers through the Lauzon auto-transformers could be substantial. A contingency involving one of these auto-transformers, or of one of the 230kV circuits C23Z or C24Z, which would result in the loss of an auto-transformer by configuration, could result in overloading of the companion auto-transformer.

While a Mode 1 split of the 115kV system would reduce the transfers through the remaining auto-transformer at Lauzon TS, it would only be sufficient to reduce the transfers to within its 10-day rating if the TransAlta (Windsor) facility were to be in-service.

In addition, if the condition were due to a permanent line fault, then the transfers on the remaining 230kV circuit would not be acceptable if they exceeded the emergency rating of the circuit. Furthermore, with the increase in loads that has been forecast, the situation would be expected to deteriorate further.

There would appear to be a number of options that could be implemented to address the concerns that have been identified with the Lauzon supply point. Some of the more obvious ones that could be developed either individually or in combination with some of the others, are listed below:

- transfer some of the load that is presently supplied from circuits K2Z & K6Z on to another supply point.
- with the proposed increase in the *continuous* rating of the JxE circuits, install facilities to allow the 115kV system to be split at Lauzon TS (as well as at Essex TS).
- install switching facilities between the four, existing 230kV circuits at Sandwich Junction and install a third 230kV circuit, terminated via a new 230/115kV auto-transformer, and connect it to the 115kV busbar at Lauzon TS.
- establish a new 230kV busbar at Lauzon TS and install a third auto-transformer.
- install a new 230kV circuit between Keith TS and either Sandwich Junction or Lauzon TS.

A new 230kV circuit between Keith TS and a new 230kV busbar at Lauzon TS would appear to be especially attractive since it would reduce the impact of a double-circuit contingency involving either circuits C21J & C22J or circuits C23Z & C24Z.

11. Conclusions & Recommendations

This Assessment has concluded that the proposed connection of the new DaimlerChrysler TS to circuits Z1E & Z7E will not materially reduce the *present* level of reliability or the load-meeting capability of the existing facilities.

However, concerns have been identified regarding the ability of the existing transmission facilities in the Windsor area to reliably supply the existing loads under contingency conditions.

Since these concerns are considered to relate to existing system deficiencies, the IMO expects that Hydro One will respond with suitable proposals that would adequately address them.

Priorities

The IMO considers that immediate action is required to permit a Mode 1 split of the Windsor area 115kV system to be initiated for contingencies that involve circuit J3E or J4E. This would require the *emergency* ratings for circuits J3E & J4E to be increased to the values shown below.

Proposed Ratings for Circuits J3E & J4E			
<i>Circuit</i>	<i>Section</i>	<i>Emergency Rating</i>	<i>Continuous Rating</i>
J3E & J4E	Keith TS to Crawford Junction	>305MVA (1470A at 120kV)	~260MVA (1250A at 120kV)
	Crawford Junction to Essex TS	>225MVA (1080A at 120kV)	~220MVA (1060A at 120kV)

It will also be necessary to revise the termination arrangement of the circuits at Essex TS, so that a Mode 1 split of the 115kV system can be initiated following a contingency involving circuit J3E. This will require the terminations for circuits E8F and Z7E to be interchanged.

In addition, consideration should be given to increasing the *continuous* ratings of the JxE circuits. The values shown in the Table above would allow full dispatch of the ATCO Power and West Windsor Power generating facilities while transfers equal to their nameplate ratings are being made through the two 125MVA auto-transformers at Keith TS.

The proposed increase in both the *emergency* and the *continuous* transfer capability of the Keith TS to Essex TS interface is expected to reduce the need for initiating splitting of the 115kV system in response to high transfers through the 115kV system or to contingencies involving those facilities that are directly associated with Keith TS. However, with the capability to supply a greater portion of the Windsor area load from Keith TS it is recommended that consideration be given to installing facilities to allow the 115kV system to be split at Lauzon TS in response to contingencies involving either of the auto-transformers at Lauzon TS.

Following the proposed enhancement of the transfer capability of the Keith TS to Essex TS interface, the remaining 115kV circuit, J3E or J4E, or the remaining auto-transformer at Keith TS could become the limiting element, depending on the status of the generation capacity at Keith TS. Consequently, in addition to increasing the transfer capability of the Keith TS to Essex TS interface, it would also be necessary to enhance the Windsor area Overload Protection Scheme so that splitting of the 115kV system could be initiated for each of these individual contingency conditions.

While the proposed increases in both the *continuous* and the *emergency* ratings of circuits J3E & J4E, together with the possible introduction of a further location at which to split the 115kV system (at Lauzon TS), would provide some immediate relief for the Windsor area, the area would still be at considerable risk in the event of a double-circuit contingency. It is therefore recommended that Hydro One review the configuration of the existing facilities in the Windsor area to determine a suitable plan for reducing that risk.

Furthermore, should it be determined that further short-term relief could be provided by transferring some of the load that is presently supplied from circuits K2Z & K6Z to a new supply point then this would be very attractive, especially if it were to reduce the present exposure of these radially-connected loads to possible supply interruptions.

12. Need for a System Impact Assessment

Based on the results of this assessment it has been concluded that all the necessary analysis to determine the impact that the proposed DaimlerChrysler TS would have on the IMO-controlled grid has been undertaken.

A separate System Impact Assessment is therefore not considered to be necessary for this Project.

13. Customer Impact Assessment

Hydro One Networks Inc., in consultation with the IMO, has concluded that this Project will have no adverse impact on any other customers in the area and that a detailed Customer Impact Assessment will not be required.

14. Notification of Approval of the Connection Proposal

Based on the results of this Assessment it is recommended that a *Notification of Approval for Connection* be issued for this Project.

TABLE 1 Forecast Loads for the Windsor Area 115kV Transformer Stations

Transformer Station	Summer Peak Load (MVA)								
	2002	2003	2004	2005	2006	2007	2008	2009	2010
Crawford TS	89	90	91	92	93	94	95	96	97
Walker TS No. 1	73	74	62	63	64	65	66	67	68
Walker TS No. 2	72	73	74	75	76	77	78	79	80
Essex TS	45	46	46	47	47	48	48	48	49
<i>Sub-total</i>	<i>279</i>	<i>283</i>	<i>273</i>	<i>277</i>	<i>280</i>	<i>284</i>	<i>287</i>	<i>290</i>	<i>294</i>
<i>Total Windsor Area Automotive Load</i>									
<ul style="list-style-type: none"> Supplied from circuits Z1E & Z7E (including new DaimlerChrysler facility load) 	30	30	60	61	62	63	64	65	66
<ul style="list-style-type: none"> Supplied from circuits E8F & E9F 	130	131	133	134	136	138	139	141	143
Total	439	444	466	472	478	485	490	496	503

TABLE 2 Load Distribution following a split of the 115kV system at Essex TS

	Summer Peak Load (MVA)								
	2002	2003	2004	2005	2006	2007	2008	2009	2010
Mode 1 Split									
Total Load supplied via circuits J3E & J4E from Keith TS	264	267	270	273	276	280	282	285	289
Total Load supplied via circuits Z1E & Z7E from Lauzon TS	175	177	196	199	202	205	208	211	214
Total	439	444	466	472	478	485	490	496	503
Mode 2 Split									
Total Load supplied via circuits J3E & J4E from Keith TS	89	90	91	92	93	94	95	96	97
Total Load supplied via circuits Z1E & Z7E from Lauzon TS	350	354	375	380	385	391	395	400	406
Total	439	444	466	472	478	485	490	496	503

TABLE 3 Loading on the Keith TS & Lauzon TS auto-transformers following a split of the 115kV system at Essex TS

	Summer Peak Load (MVA)								
	2002	2003	2004	2005	2006	2007	2008	2009	2010
Mode 1 Split									
Total Load supplied via circuits J3E & J4E from Keith TS	264	267	270	273	276	280	282	285	289
115kV load supplied from the busbar at Keith TS	25	25	26	26	27	27	28	28	29
Sub-total	289	292	296	299	303	307	310	313	318
Total Load supplied via circuits Z1E & Z7E from Lauzon TS	175	177	196	199	202	205	208	211	214
Total load at Kingsville TS, Tilbury West DS & Tilbury TS	176	179	182	186	189	193	196	200	203
Sub-total	351	356	378	385	391	398	404	411	417
Total	640	648	674	684	694	705	714	724	735
Mode 2 Split									
Total Load supplied via circuits J3E & J4E from Keith TS	89	90	91	92	93	94	95	96	97
115kV load supplied from the busbar at Keith TS	25	25	26	26	27	27	28	28	29
Sub-total	114	115	117	118	120	121	123	124	126
Total Load supplied via circuits Z1E & Z7E from Lauzon TS	350	354	375	380	385	391	395	400	406
Total load at Kingsville TS, Tilbury West DS & Tilbury TS	176	179	182	186	189	193	196	200	203
Sub-total	526	533	557	566	574	584	591	600	609
Total	640	648	674	684	694	705	714	724	735

TABLE 4 Ratings of Transmission Facilities in the Windsor Area

Circuit	Section	Conductor Sag Temperature	Summer Rating: 30°C ambient & 4km/hr wind [MVA ratings at 242kV]			
			Continuous at 93°C	Emergency: at 127°C or sag temp. if lower	15-minute LTR at sag temp. *	
230kV Circuits						
C21J	Chatham SS to Sandwich Junction	123°C	1120A [469MVA]	1410A [591MVA]	1640A [687MVA]	
	Sandwich Junction to Keith TS	116°C	880A [369MVA]	1050A [440MVA]	1180A [495MVA]	
C22J	Chatham SS to Sandwich Junction			121°C	1090A [457MVA]	1210A [507MVA]
	Sandwich Junction to Malden Junction	1050A [440MVA]			1180A [495MVA]	
	Malden Junction to Keith TS	116°C				
C23Z	Chatham TS to Lauzon TS	127°C	1120A [469MVA]	1440A [604MVA]	1680A [704MVA]	
C24Z	Chatham SS to Sandwich Junction	116°C	880A [369MVA]	1050A [440MVA]	1180A [495MVA]	
	Sandwich Junction to Lauzon TS		1120A [469MVA]	1350A [566MVA]	1570A [658MVA]	
Circuit	Section	Conductor Sag Temperature	Summer Rating: 30°C ambient & 4km/hr wind [MVA ratings at 124kV]			
			Continuous at 93°C	Emergency: at 127°C or sag temp. if lower	15-minute LTR at sag temp. *	
115kV Circuits						
J3E	Keith TS to Crawford Junction	150°C	850A [183MVA]	1090A # [234MVA]	1420A [305MVA]	
J4E		116°C		1020A [219MVA]	1140A [245MVA]	
Z1E	Lauzon TS to Jefferson Junction	127°C	950A [204MVA]	1220A [262MVA]	1420A [305MVA]	
Z7E						
230/115kV Auto-transformers			Rating: 30°C ambient & pre-loading at continuous rating [MVA rating at 124kV]			
			Continuous	10-day	2-hour	15-min LTR
T11	Keith TS	672A [144MVA]	859A [184MVA]	910A [195MVA]	1083A [233MVA]	
T12		610A [131MVA]	759A [163MVA]	780A [167MVA]	894A [192MVA]	
T1	Lauzon TS	250MVA	296.8MVA	326.2MVA	364.2MVA	
T2						

Note: * Assumes a pre-loading of 75% of the emergency rating of the conductor.
 # Emergency rating is calculated at 127°C or the sag temperature, if this is lower.
 15-minute LTR is calculated at the sag temperature of 150°C

TABLE 5 Summary of the Performance of the Windsor Area Transmission System		
<i>Contingency Condition</i>	<i>Mode 1 Split of the Essex 115kV busbar</i>	<i>Mode 2 Split of the Essex 115kV busbar</i>
<i>With the West Windsor Power & TransAlta (Windsor) generating facilities out-of-service</i>		
None	Transfers through the Keith auto-transformers remain within their 10-day rating. Transfers through the Lauzon auto-transformers remain within their continuous rating.	Transfers through the Keith auto-transformers remain within their continuous rating. Transfers through the Lauzon auto-transformers remain within their 10-day rating.
J3E or J4E	Emergency/15-minute rating of companion circuit exceeded	Continuous rating of companion circuit respected.
J3E & J4E <i>(Initiates a Mode 2 split of the Essex busbar)</i>	<i>Not applicable</i>	<i>No additional overloads</i>
Z1E or Z7E	Continuous rating of companion circuit respected	15-minute rating of companion circuit exceeded
Z1E & Z7E <i>(Initiates a Mode 1 split of the Essex busbar)</i>	<i>No additional overloads</i>	<i>Not applicable</i>
Auto-transformer T11 or T12 at Keith TS	15-min LTR of companion auto-transformer exceeded	Continuous rating of companion auto-transformer respected
Auto-transformer T1 or T2 at Lauzon TS	15-min LTR of companion auto-transformer exceeded.	15-min LTR of companion auto-transformer exceeded
<i>With both the West Windsor Power & TransAlta (Windsor) generating facilities in-service</i>		
None	Transfers through the Keith auto-transformers remain within their continuous rating. Transfers through the Lauzon auto-transformers remain within their continuous rating.	Transfers through the Keith auto-transformers remain within their continuous rating. Transfers through the Lauzon auto-transformers remain within their continuous rating.
J3E or J4E	Emergency/15-minute rating of companion circuit exceeded	Continuous rating of companion circuit respected
J3E & J4E <i>(Initiates a Mode 2 split of the Essex busbar)</i>	<i>Not applicable</i>	<i>No additional overloads</i>
Z1E or Z7E	Continuous rating of companion circuit respected	Emergency rating of companion circuit exceeded
Z1E & Z7E <i>(Initiates a Mode 1 split of the Essex busbar)</i>	<i>No additional overloads</i>	<i>Not applicable</i>
Auto-transformer T11 or T12 at Keith TS	10-day rating of companion auto-transformer respected	Continuous rating of companion auto-transformer respected
Auto-transformer T1 or T2 at Lauzon TS	10-day rating of companion auto-transformer exceeded	15-min LTR of companion auto-transformer exceeded

Lauzon TS - 115kV : Recorded Voltages for the Year 2001

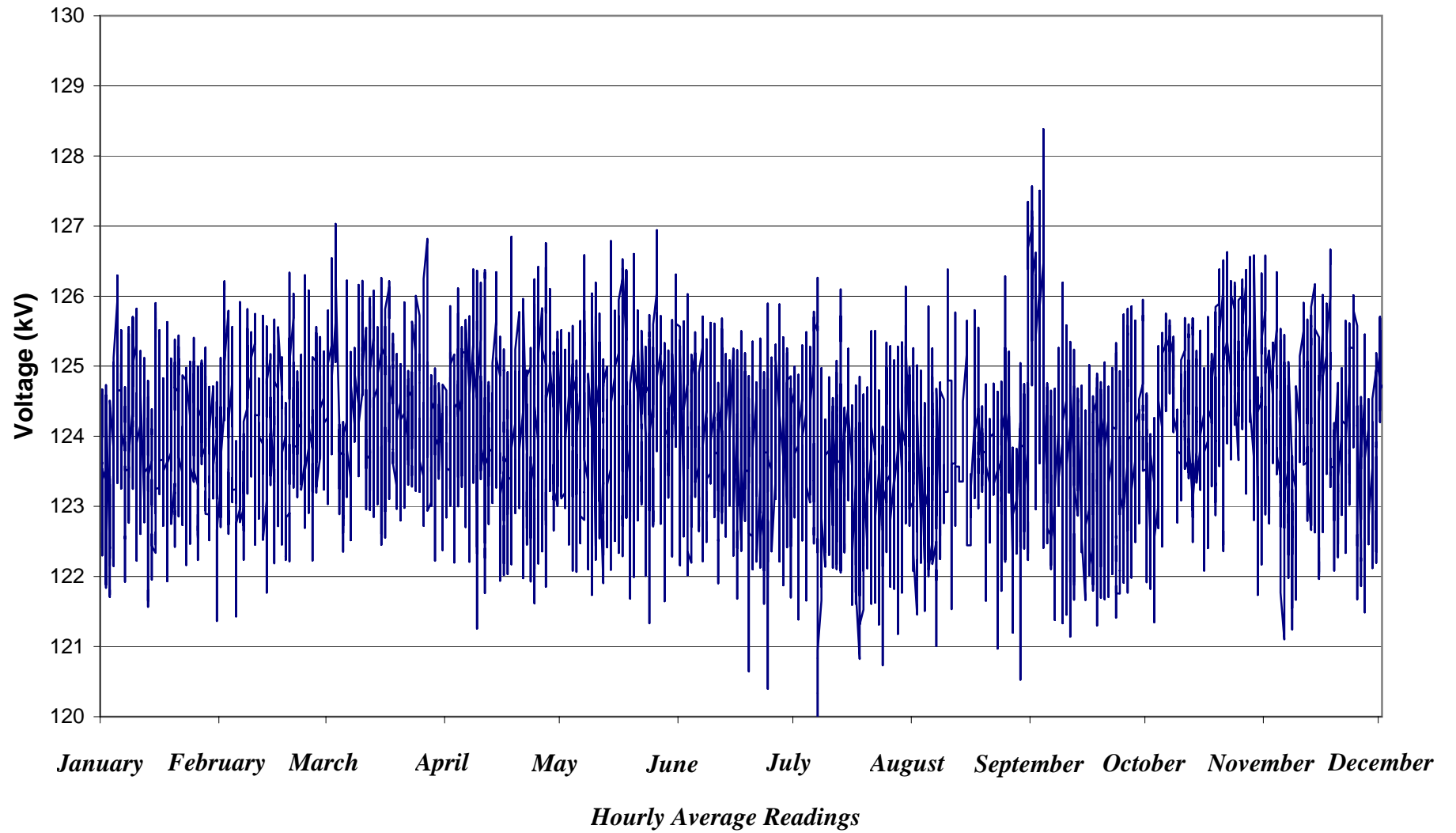
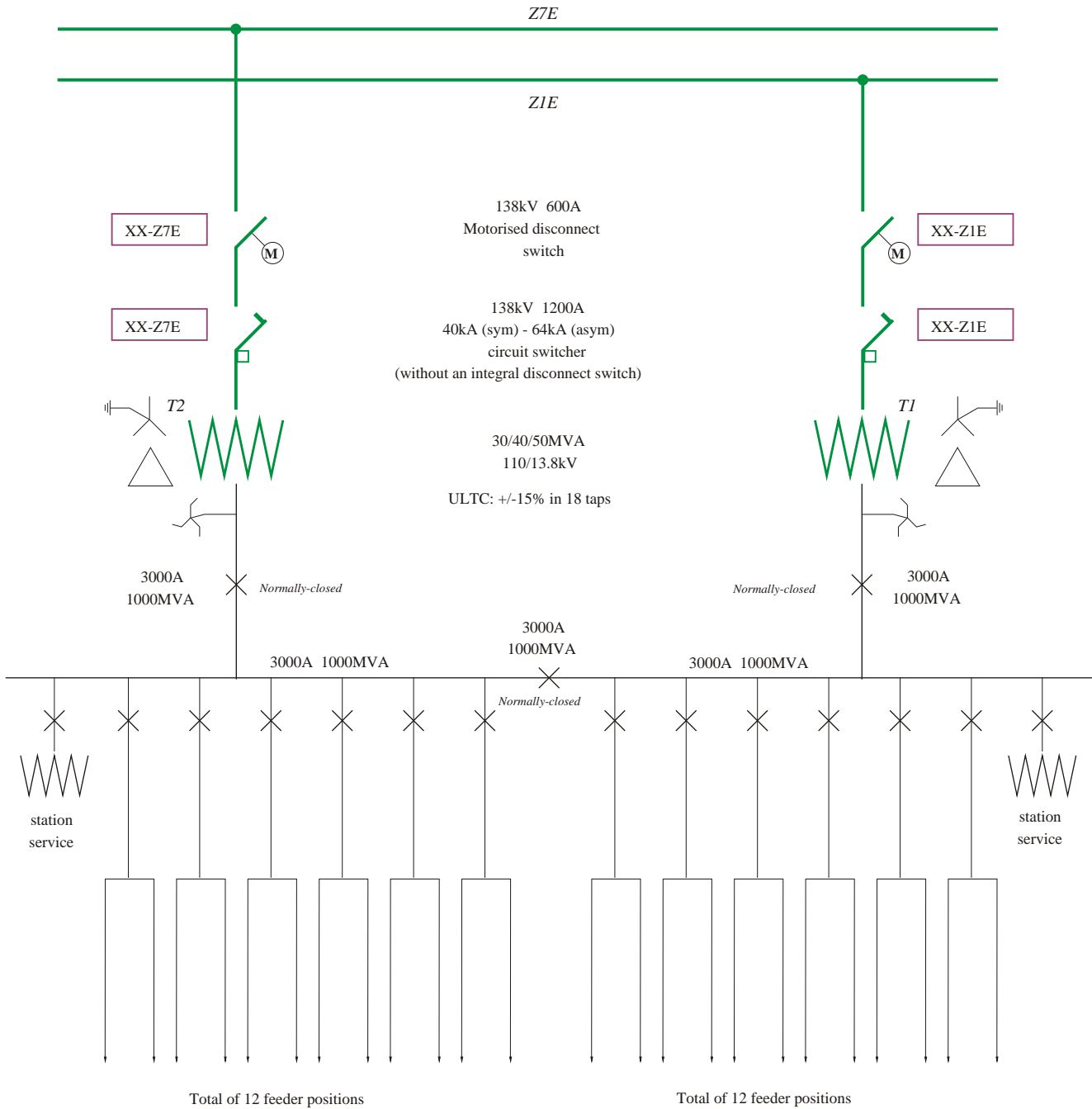

FIGURE 1



XX-Z7E Nomenclature to be provided by Hydro One

Proposed facilities at DaimlerChrysler Pillette Road Substation

DIAGRAM 1

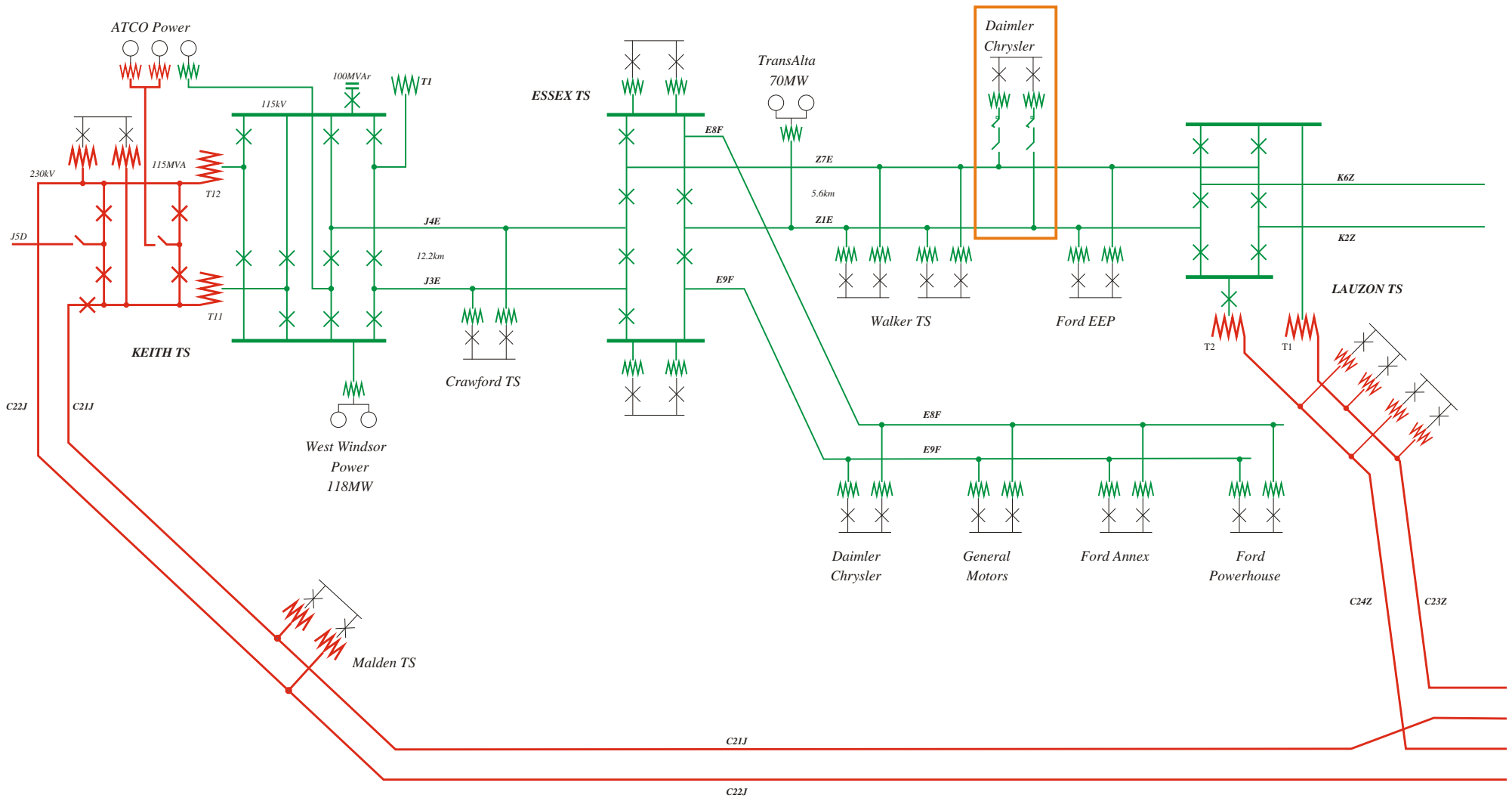

Transmission Facilities in the Windsor Area

DIAGRAM 2

19th July 2002

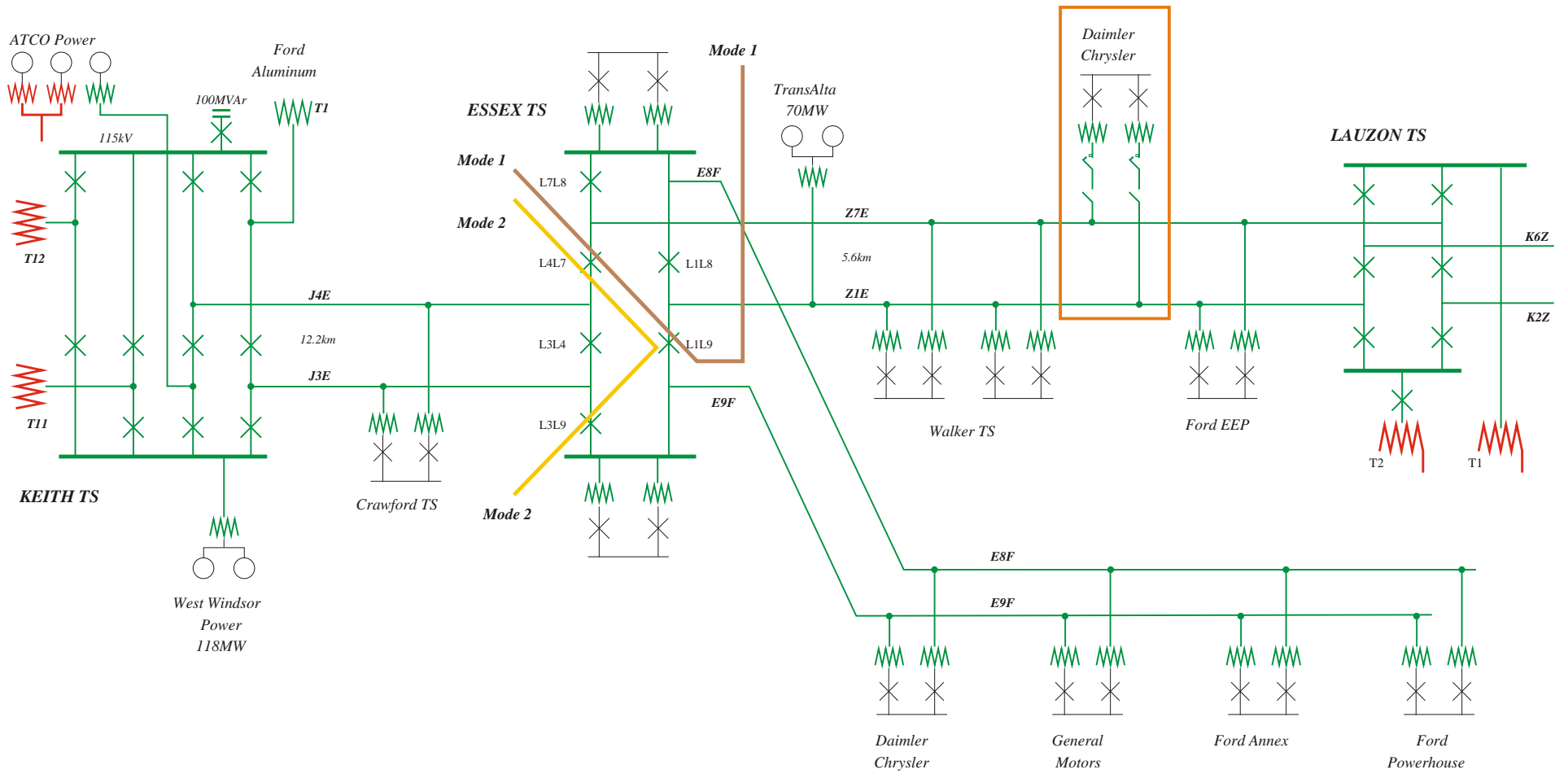

Windsor Area Overload Protection Scheme
Options Available for Splitting the Windsor Area 115kV System

DIAGRAM 3

18th July 2002

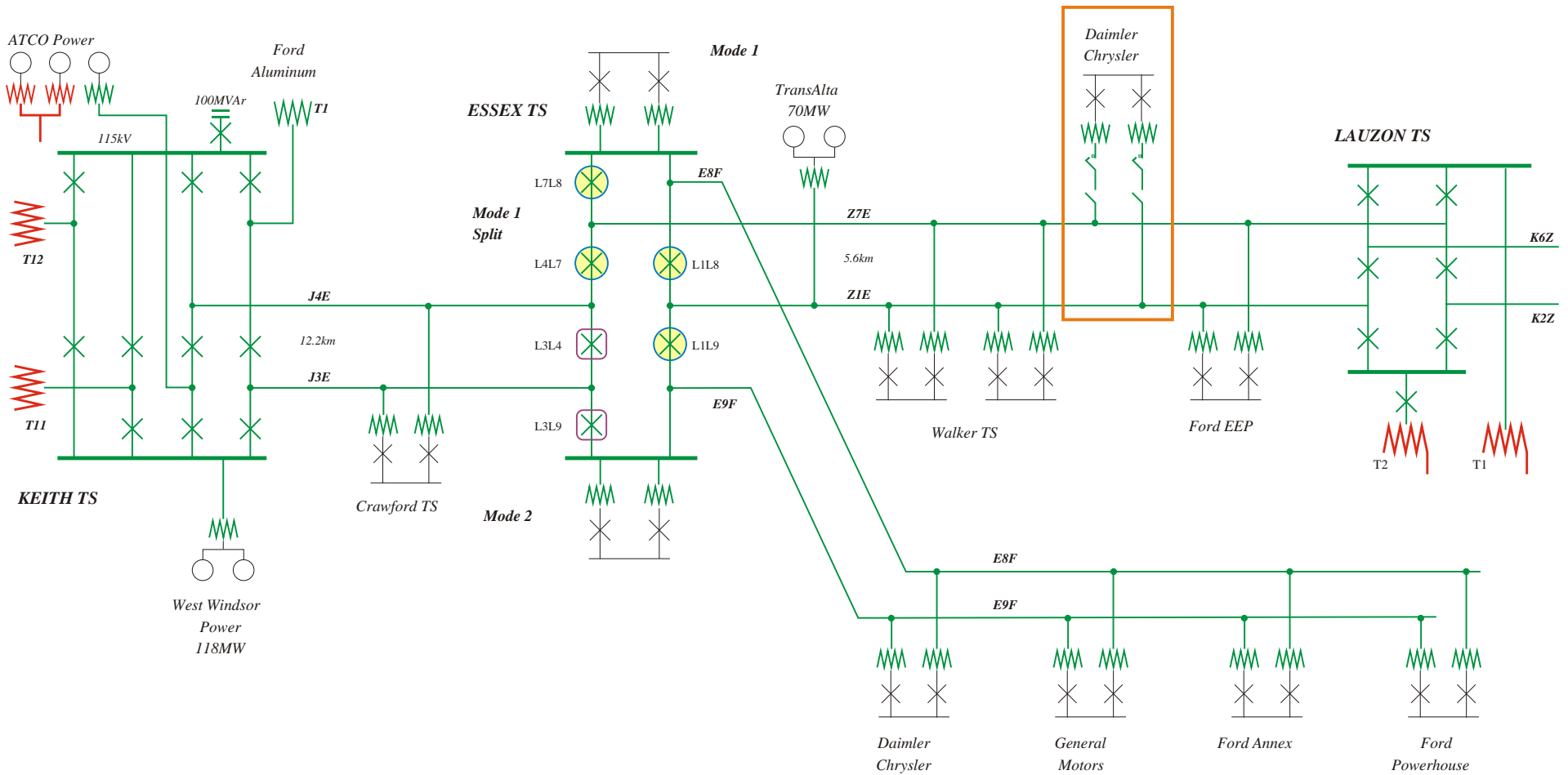

Breakers that would open for a J3E contingency



Breakers that would need to be opened for a Mode 1 Split of the 115kV system

Windsor Area Overload Protection Scheme
Effect of a Mode 1 Split in Response to a J3E Contingency

DIAGRAM 4

4rd August 2002

EXISTING

The busbar position directly adjacent to circuit J4E is presently occupied by circuit Z7E

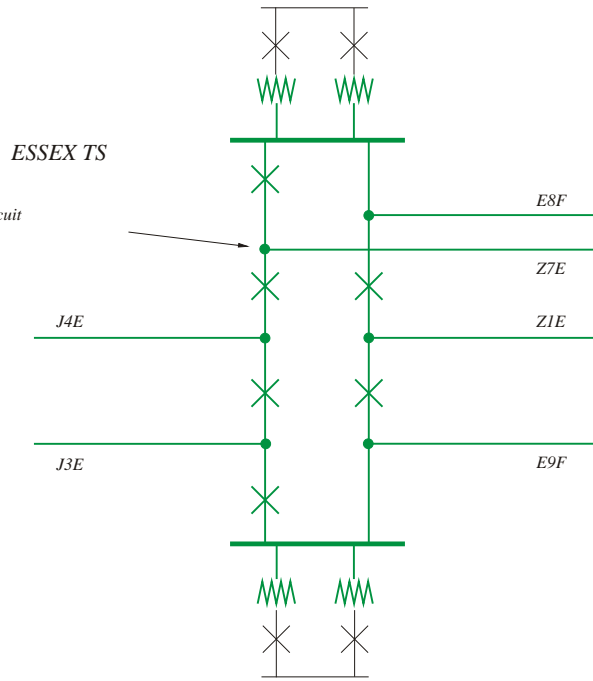

PROPOSED

To allow a Mode 1 split for a contingency involving either of the Keith TS to Essex TS circuits, the busbar positions directly adjacent to these circuits must be occupied by one of the ExF circuits

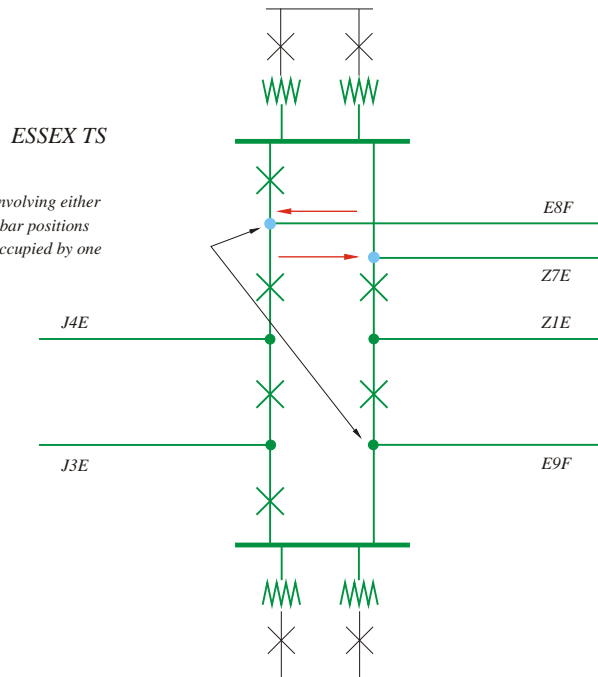

Proposed Revision of the Existing Terminations at Essex TS

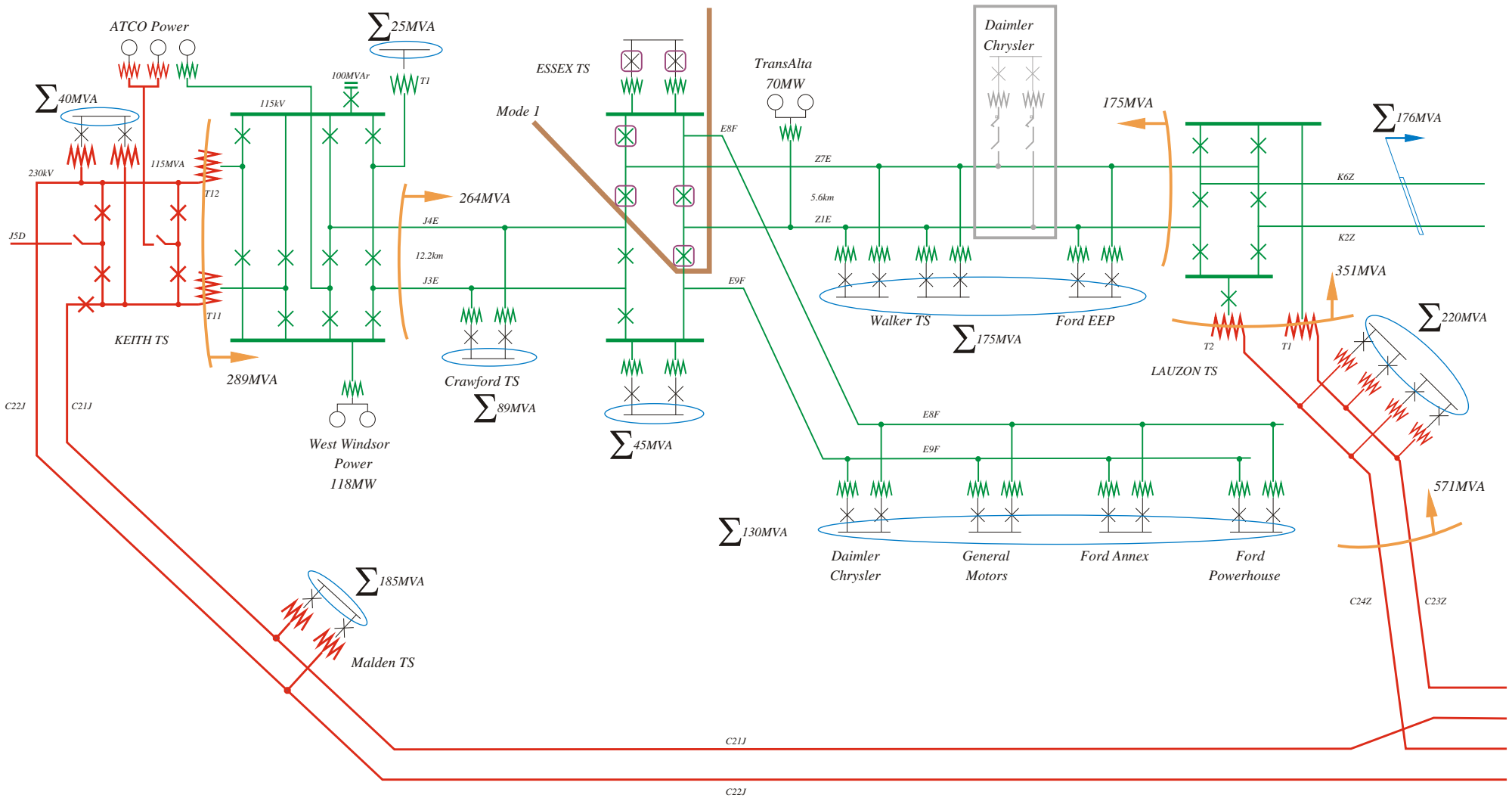

Breakers to be opened for a Mode 1 Split

Flow Distribution Resulting from a Mode 1 Split
 with West Windsor Power & TransAlta (Windsor) generation out-of-service

(losses would increase flows by between 4% & 6%)

Summer-2002 Loads

DIAGRAM 6

4th August 2002

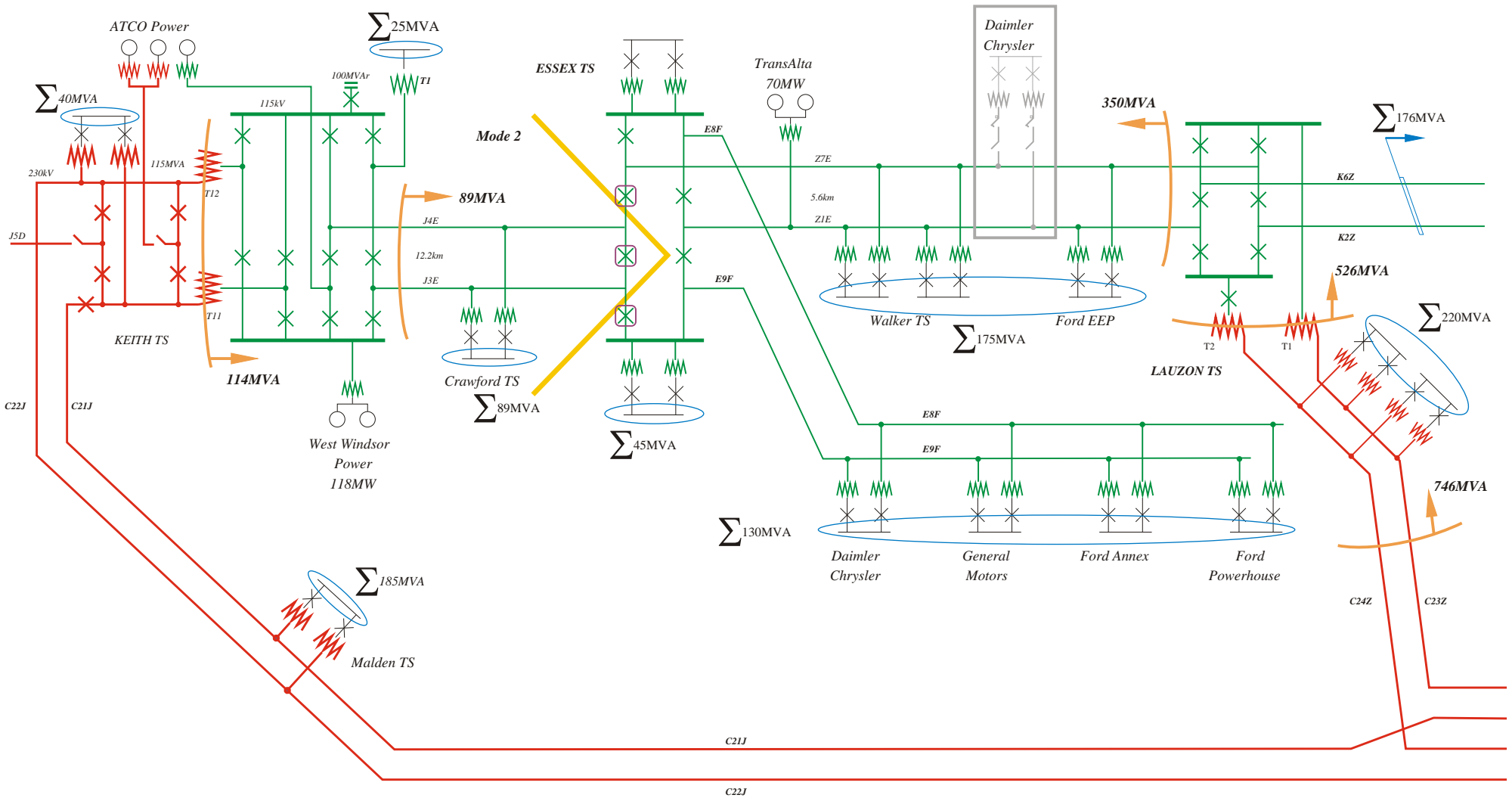

 Breakers to be opened for a Mode 2 Split

Flow Distribution Resulting from a Mode 2 Split
 with West Windsor Power & TransAlta(Windsor) generation out-of-service
 (losses would increase flows by between 4% & 6%)

Summer-2002 Loads

DIAGRAM 7

4th August 2002